

**DRAWING DISCLAIMER**  
 COPYRIGHT OF THIS DRAWING IS RESERVED BY BIL GROUP LTD. IT IS ISSUED ON CONDITION THAT IT IS NOT REPRODUCED, COPIED, OR DISCLOSED TO A THIRD PARTY EITHER WHOLLY OR IN PART WITHOUT THE CONSENT IN WRITING OF BIL GROUP LTD.

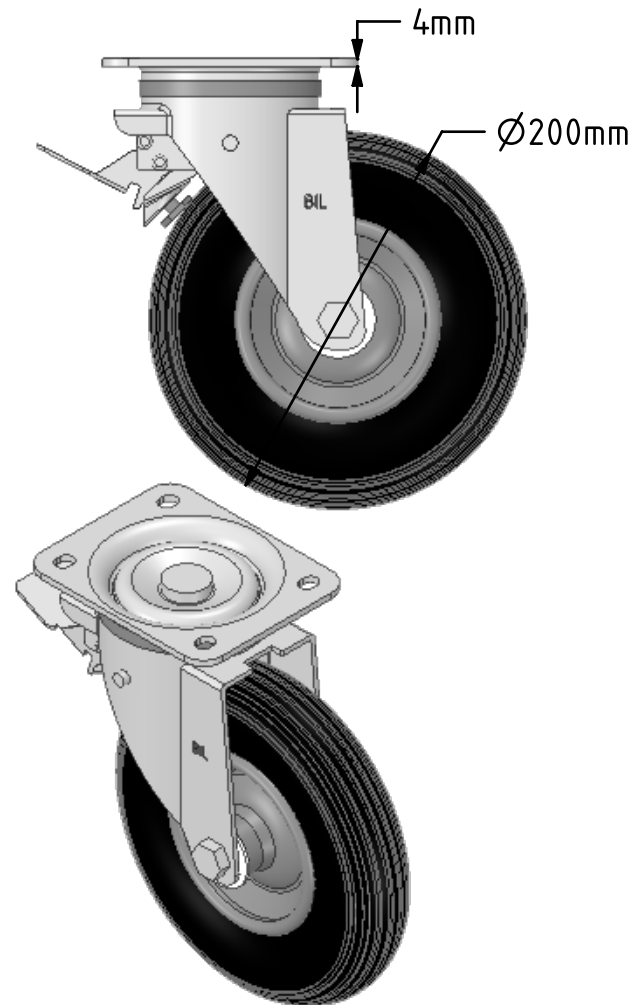

**Description:**  
 BZPC200MRBSWB

Pressed steel swivel castor with a top plate fixing fitted with a black pneumatic tyre steel centred wheel (2 ply) with a roller bearing and total lock brake. Wheel diameter 200mm, tread width 44mm, overall height 238mm, top plate 135mm x 110mm, hole centres 105mm x 80mm. Load capacity 75kg.

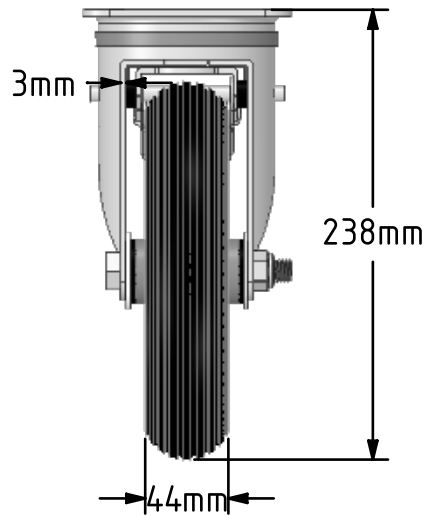
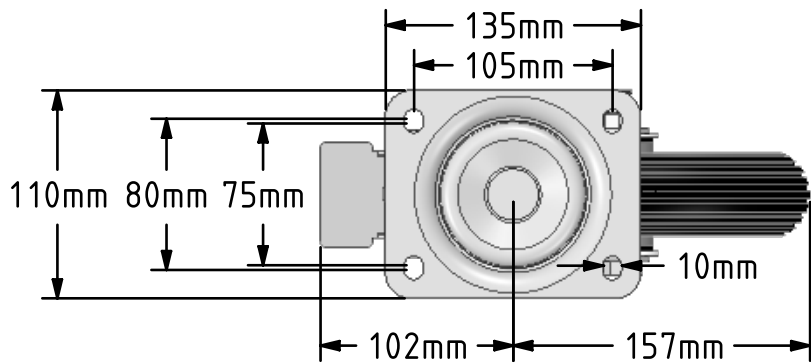

	NAME	DATE
DRAWN	Matt	28/01/19
APPROVED BY	Chris	28/01/19
SCALE	1:4	28/01/19
WEIGHT	2.56kg	28/01/19

UNLESS OTHERWISE SPECIFIED DIMENSIONS ARE IN MILLIMETRES  
 Unspecified Tolerances  
 Machining ± 0.25mm  
 Fabrication ± 1mm

 BIL Group Ltd, Porte Marsh Road, Calne Wiltshire, SN11 9BW, United Kingdom Tel +44 (0)1249 822 222 Fax: +44 (0)1249 822 300 www.bilgroup.co.uk		TITLE	
		BZPC200MRBSWB	
SIZE	DWG NO.	REV	
A4	BILCW03BZPC200MRBSWB_01	1	
FILE NAME	BILCW03BZPC200MRBSWB_01.PDF SHEET 1 OF 1		