

DRAWING DISCLAIMER
 COPYRIGHT OF THIS DRAWING IS RESERVED BY BIL GROUP LTD. IT IS ISSUED ON CONDITION THAT IT IS NOT REPRODUCED, COPIED, OR DISCLOSED TO A THIRD PARTY EITHER WHOLLY OR IN PART WITHOUT THE CONSENT IN WRITING OF BIL GROUP LTD.

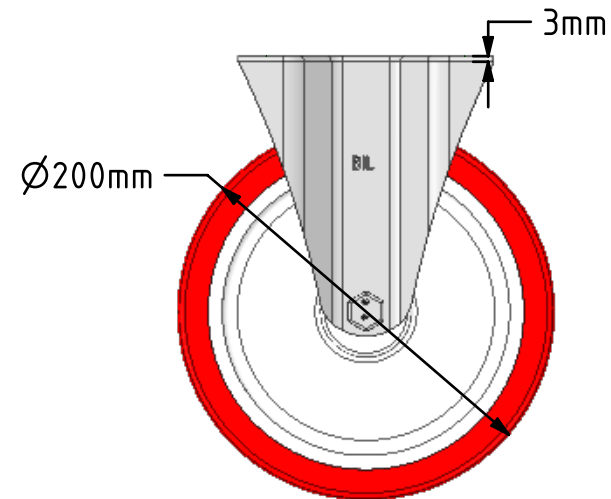

Description:
 BZMMF200NPB

Pressed steel fixed castor with a top plate fitted with a red polyurethane tyre on white nylon cantered wheel with roller bearings, wheel diameter 200mm, tread width 50mm, overall height 235mm, top plate 135mm x 110mm with hole centres 105 x 80mm, with a load capacity of 400kg.

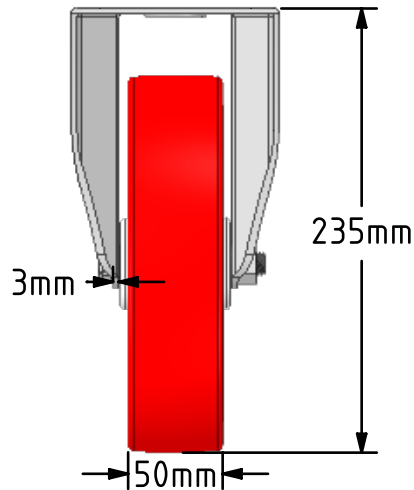
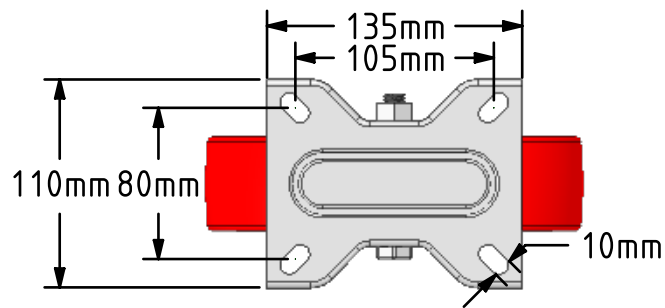
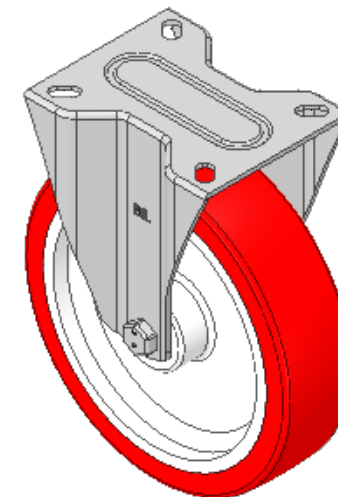
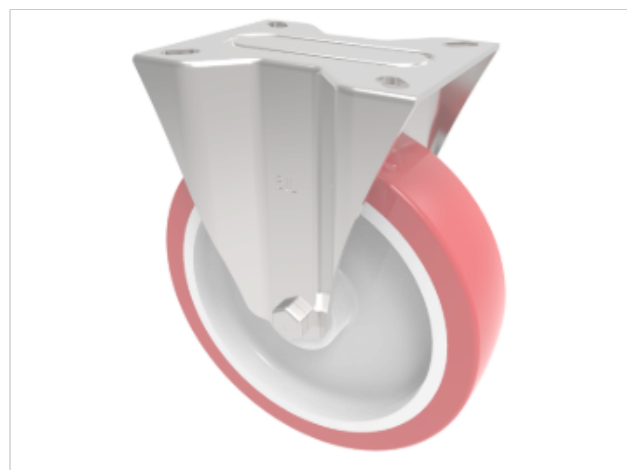

	NAME	DATE
DRAWN	Matt	06/03/19
APPROVED BY	Tim W	06/03/19
SCALE	1:4	06/03/19
WEIGHT	2.061kg	06/03/19

UNLESS OTHERWISE SPECIFIED DIMENSIONS ARE IN MILLIMETRES
 Unspecified Tolerances
 Machining ± 0.25mm
 Fabrication ± 1mm

 BIL Group Ltd, Porte Marsh Road, Calne
 Wiltshire, SN11 9BW, United Kingdom
 Tel +44 (0)1249 822 222 Fax: +44 (0)1249 822 300
 www.bilgroup.co.uk

TITLE		
BZMMF200NPB		
SIZE	DWG NO.	REV
A4	BILCW03BZMMF200NPB__02	2
FILE NAME	BILCW03BZMMF200NPB__02.PDF SHEET 1 OF 1	