

**DRAWING DISCLAIMER**  
 COPYRIGHT OF THIS DRAWING IS RESERVED BY BIL GROUP LTD. IT IS ISSUED ON CONDITION THAT IT IS NOT REPRODUCED, COPIED, OR DISCLOSED TO A THIRD PARTY EITHER WHOLLY OR IN PART WITHOUT THE CONSENT IN WRITING OF BIL GROUP LTD.

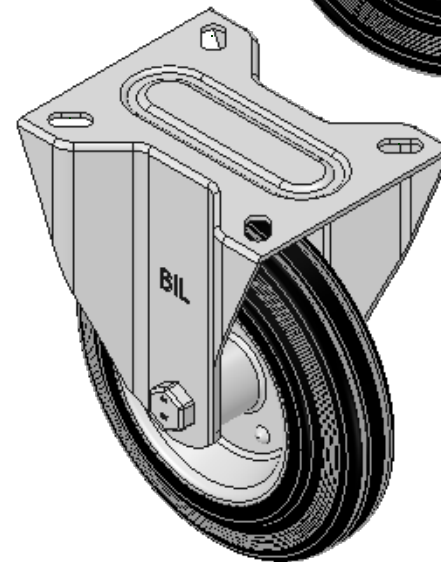

**Description:**  
 BZMMF160BSB

Pressed steel fixed castor with top plate fixing fitted with black rubber tyre on steel disc centre with roller bearing. Wheel diameter 160mm, tread width 40mm, overall height 195mm, plate size 135mm x 110mm, hole centres 105mm x 80mm. Load capacity 160kg.

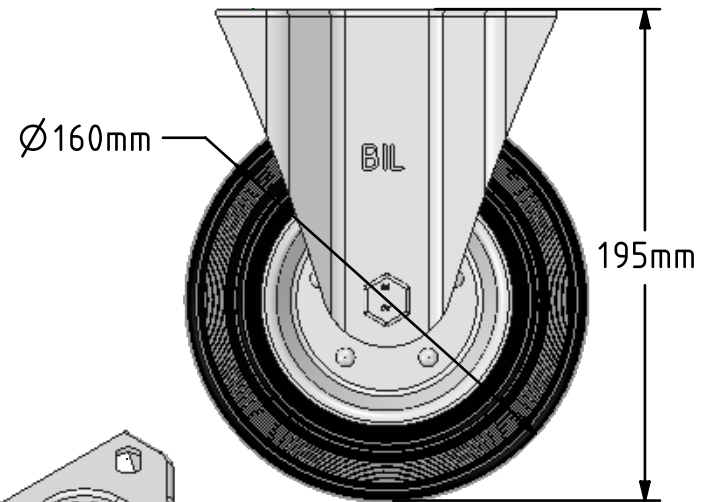
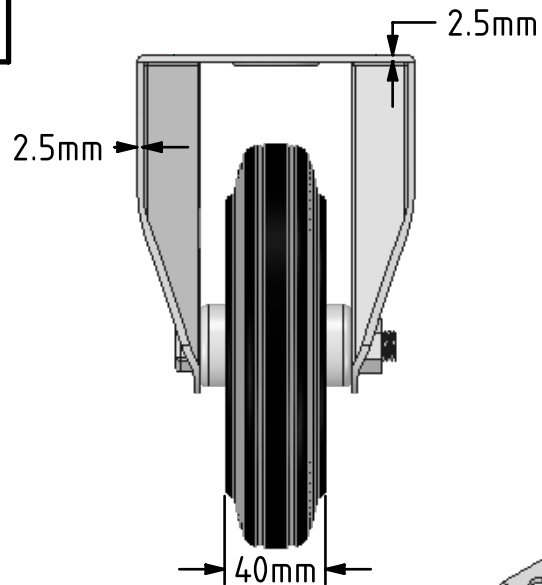
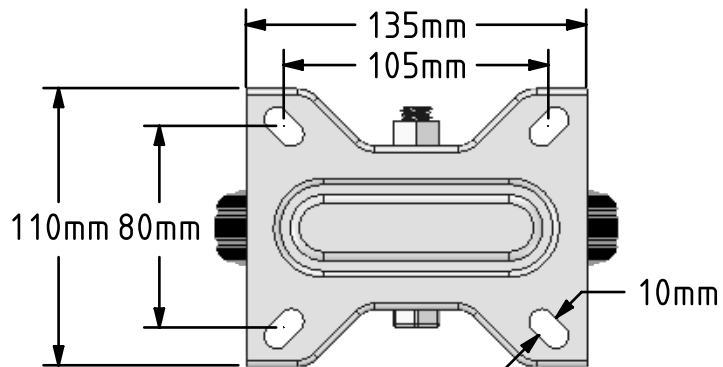

	NAME	DATE
DRAWN	Matt	10/07/18
APPROVED BY		10/07/18
SCALE	1:3	10/07/18
WEIGHT	1.702kg	10/07/18

UNLESS OTHERWISE SPECIFIED DIMENSIONS ARE IN MILLIMETRES  
 Unspecified Tolerances  
 Machining ± 0.25mm  
 Fabrication ± 1mm

 BIL Group Ltd, Porte Marsh Road, Calne Wiltshire, SN11 9BW, United Kingdom  
 Tel +44 (0)1249 822 222 Fax: +44 (0)1249 822 300  
 www.bilgroup.co.uk

TITLE  
**BZMMF160BSB**

SIZE	DWG NO.	REV
A4	BILCW03BZMMF160BSB_01	1
FILE NAME	BILCW03BZMMF160BSB_01.PDF SHEET 1 OF 1	