

DRAWING DISCLAIMER
 COPYRIGHT OF THIS DRAWING IS RESERVED BY BIL GROUP LTD. IT IS ISSUED ON CONDITION THAT IT IS NOT REPRODUCED, COPIED, OR DISCLOSED TO A THIRD PARTY EITHER WHOLLY OR IN PART WITHOUT THE CONSENT IN WRITING OF BIL GROUP LTD.

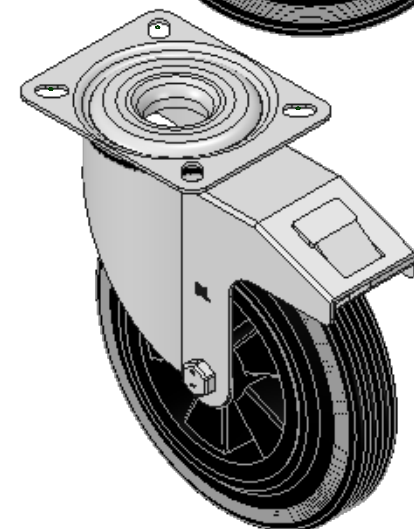

Description:
 BZMM200PSBSWB

Pressed steel swivel castor with a top plate fixing fitted with a black rubber tyre on black polypropylene centred wheel with a roller bearing and total lock brake. Wheel diameter 200mm, tread width 50mm, overall height 235mm, top plate 135mm x 110mm, hole centres 105mm x 80mm. Load capacity 205kg.

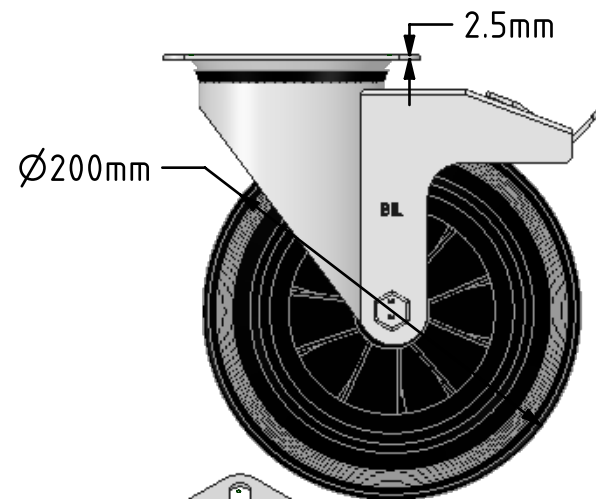
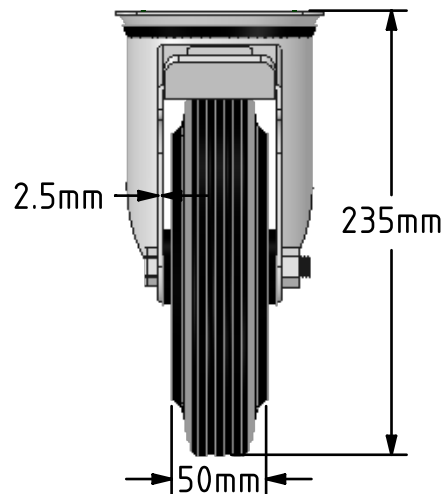
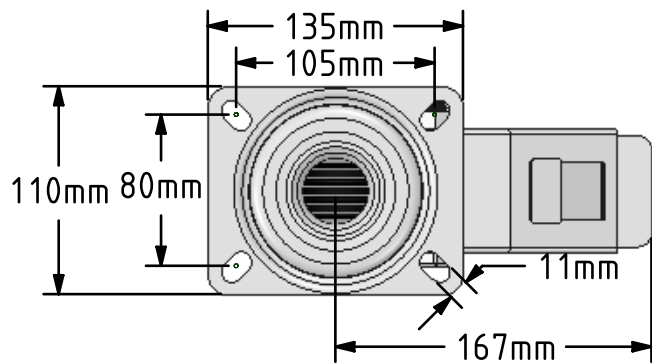

	NAME	DATE
DRAWN	Matt	03/08/18
APPROVED BY	Chris	03/08/18
SCALE	1:4	03/08/18
WEIGHT	2.789kg	03/08/18

 BIL Group Ltd, Porte Marsh Road, Calne
 Wiltshire, SN11 9BW, United Kingdom
 Tel +44 (0)1249 822 222 Fax: +44 (0)1249 822 300
 www.bilgroup.co.uk

TITLE	BZMM200PSBSWB	
-------	---------------	--

UNLESS OTHERWISE SPECIFIED DIMENSIONS ARE IN MILLIMETRES
 Unspecified Tolerances
 Machining ± 0.25mm
 Fabrication ± 1mm

SIZE	DWG NO.	REV
A4	BILCW03BZMM200PSBSWB_01	1
FILE NAME	BILCW03BZMM200PSBSWB_01.PDF SHEET 1 OF 1	