

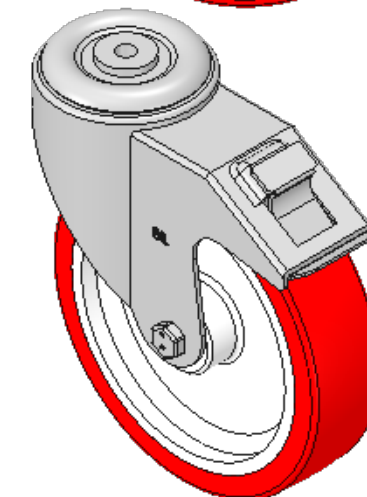

DRAWING DISCLAIMER  
 COPYRIGHT OF THIS DRAWING IS RESERVED BY BIL GROUP LTD. IT IS ISSUED ON CONDITION THAT IT IS NOT REPRODUCED, COPIED, OR DISCLOSED TO A THIRD PARTY EITHER WHOLLY OR IN PART WITHOUT THE CONSENT IN WRITING OF BIL GROUP LTD.

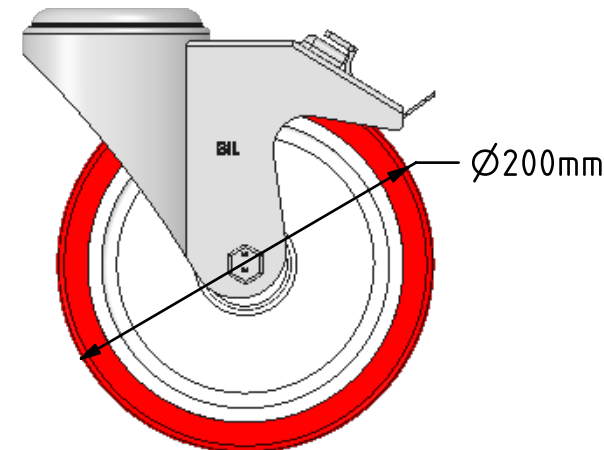
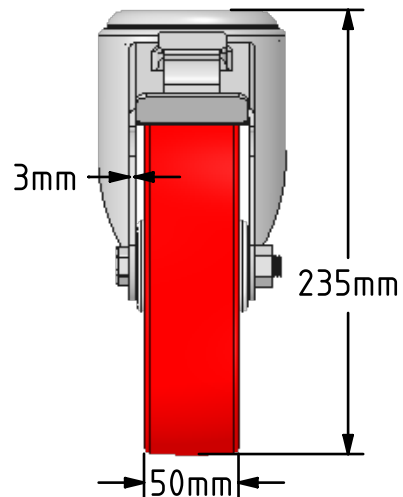
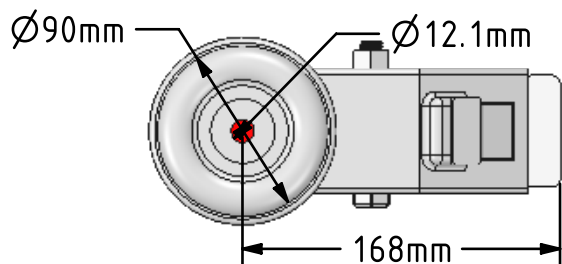

Description:  
 BZMM200NPBBH12SWB

Pressed steel swivel castor with a 12mm bolt hole fitted with a red polyurethane on white nylon centered wheel with roller bearings with total lock brake, 200mm wheel diameter 50mm tread width 235mm overall height with a load capacity of 350kgs



	NAME	DATE	 BIL Group Ltd, Porte Marsh Road, Calne Wiltshire, SN11 9BW, United Kingdom Tel +44 (0)1249 822 222 Fax: +44 (0)1249 822 300 www.bilgroup.co.uk
DRAWN	Matt	23/01/18	
APPROVED BY	Tim W	23/01/18	
SCALE	1:4	23/01/18	
WEIGHT	2.871kg	23/01/18	
UNLESS OTHERWISE SPECIFIED DIMENSIONS ARE IN MILLIMETRES  Unspecified Tolerances Machining ± 0.25mm Fabrication ± 1mm			TITLE <b>BZMM200NPBBH12SWB</b>
SIZE	DWG NO.		REV
A4	BILCW03BZMM200NPBBH12SWB_01		1
FILE NAME BILCW03BZMM200NPBBH12SWB_01.PDF SHEET 1 OF 1			