

DRAWING DISCLAIMER  
 COPYRIGHT OF THIS DRAWING IS RESERVED BY BIL GROUP LTD. IT IS ISSUED ON CONDITION THAT IT IS NOT REPRODUCED, COPIED, OR DISCLOSED TO A THIRD PARTY EITHER WHOLLY OR IN PART WITHOUT THE CONSENT IN WRITING OF BIL GROUP LTD.

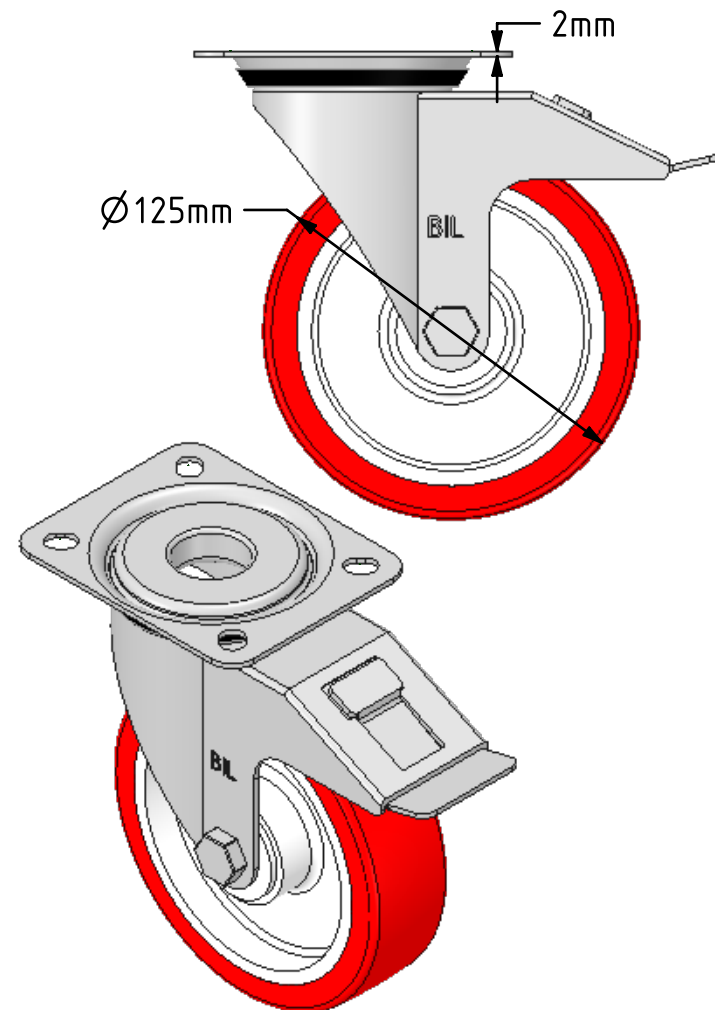

Description:  
 BZMM125NPBSWB

Pressed steel swivel castor with a top plate fitted with a red polyurethane tyre on white nylon centred wheel with roller bearings and total lock brake, 125mm wheel diameter, 35mm tread width, 155mm overall height, 105mm x 85mm top plate, 80mm x 60mm hole centres with a load capacity of 200kgs

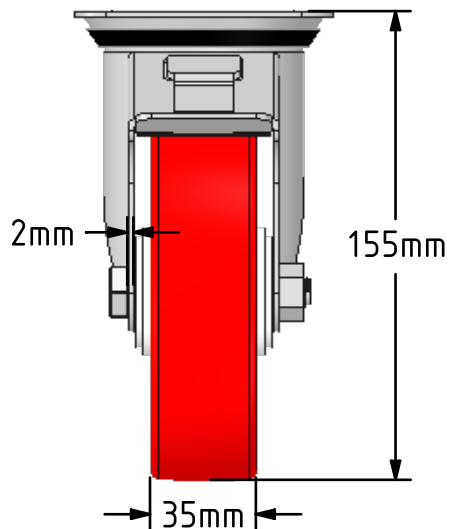
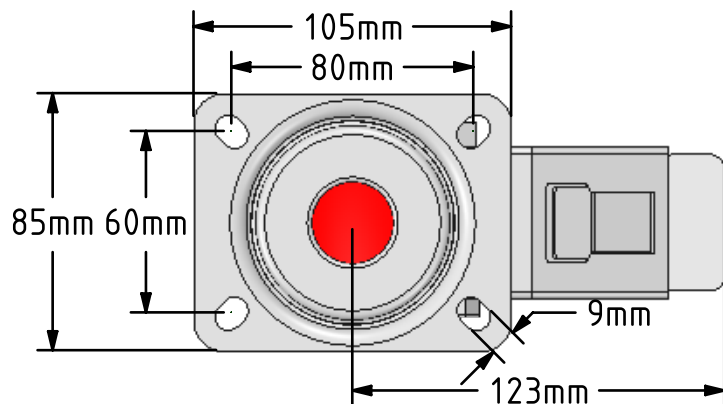

	NAME	DATE
DRAWN	Matt	01/08/18
APPROVED BY	Tim W	01/08/18
SCALE	2:5	01/08/18
WEIGHT	1.029kg	01/08/18

UNLESS OTHERWISE SPECIFIED DIMENSIONS ARE IN MILLIMETRES  
 Unspecified Tolerances  
 Machining ± 0.25mm  
 Fabrication ± 1mm

 BIL Group Ltd, Porte Marsh Road, Calne  
 Wiltshire, SN11 9BW, United Kingdom  
 Tel +44 (0)1249 822 222 Fax: +44 (0)1249 822 300  
 www.bilgroup.co.uk

TITLE  
**BZMM125NPBSWB**

SIZE	DWG NO.	REV
A4	BILCW03BZMM125NPBSWB_01	1

FILE NAME BILCW03BZMM125NPBSWB\_01.PDF SHEET 1 OF 1