

DRAWING DISCLAIMER
 COPYRIGHT OF THIS DRAWING IS RESERVED BY BIL GROUP LTD. IT IS ISSUED ON CONDITION THAT IT IS NOT REPRODUCED, COPIED, OR DISCLOSED TO A THIRD PARTY EITHER WHOLLY OR IN PART WITHOUT THE CONSENT IN WRITING OF BIL GROUP LTD.

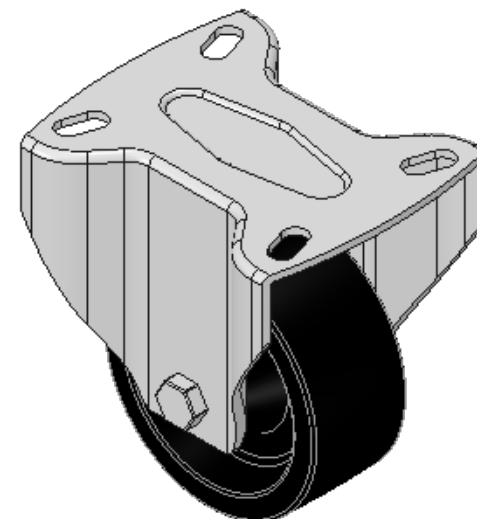

Description:
 BZMHF80AN3

Pressed steel fixed castor with a top plate fixing fitted with a black Ditherm wheel with a plain bearing. Wheel diameter 80mm, tread width 35mm, overall height 110mm top plate 100mm x 85mm, hole centres 80mm x 60mm or 75mm x 45mm. Load capacity 150kg. Max temp 300oC. REACH compliant, RoHS Compliant, USDA approved FDA approved.

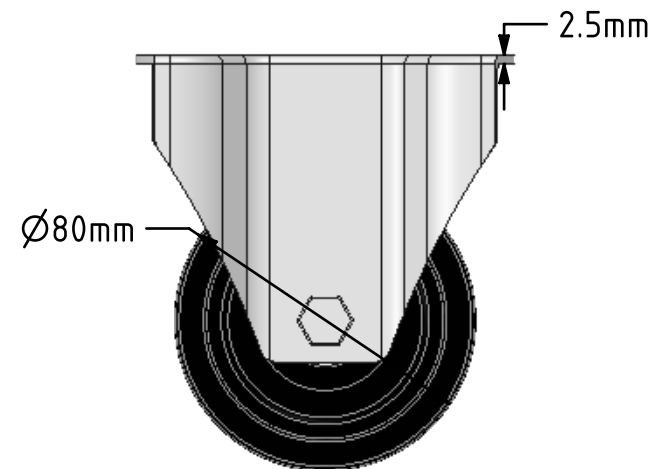
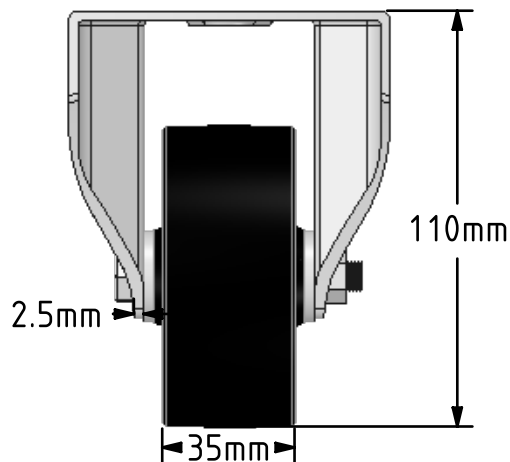
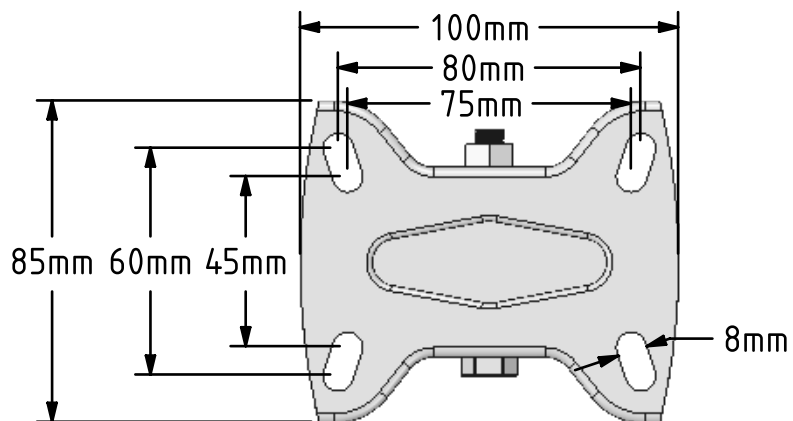

	NAME	DATE
DRAWN	Matt	09/03/18
APPROVED BY	Tim W	09/03/18
SCALE	1:2	09/03/18
WEIGHT	0.586kg	09/03/18



BIL Group Ltd, Porte Marsh Road, Calne
 Wiltshire, SN11 9BW, United Kingdom
 Tel +44 (0)1249 822 222 Fax: +44 (0)1249 822 300
 www.bilgroup.co.uk

TITLE

BZMHF80AN3

UNLESS OTHERWISE SPECIFIED DIMENSIONS ARE IN MILLIMETRES
 Unspecified Tolerances
 Machining ± 0.25mm
 Fabrication ± 1mm

SIZE	DWG NO.	REV
A4	BILCW03BZMHF80AN3_01	1
FILE NAME	BILCW03BZMHF80AN3_01.PDF	SHEET 1 OF 1