

DRAWING DISCLAIMER
 COPYRIGHT OF THIS DRAWING IS RESERVED BY BIL GROUP LTD. IT IS ISSUED ON CONDITION THAT IT IS NOT REPRODUCED, COPIED, OR DISCLOSED TO A THIRD PARTY EITHER WHOLLY OR IN PART WITHOUT THE CONSENT IN WRITING OF BIL GROUP LTD.

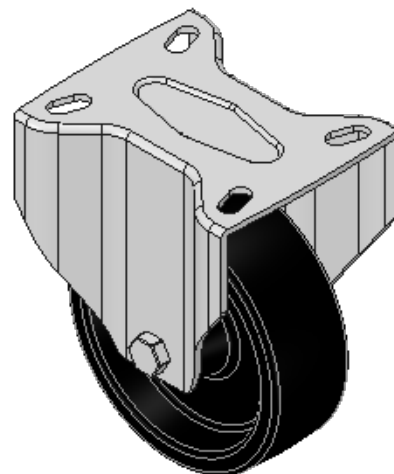

Description:
 BZMHF100LAN3

Pressed steel fixed castor with a top plate fixing fitted with a black Ditherm wheel. Wheel diameter 100mm, tread width 35mm, overall height 128mm, plate size 100mm x 85mm, hole centres 80mm x 60mm or 75mm x 45mm. Load capacity 170kg with a maximum temperature of 300c.REACH compliant, RoHs Compliant, USDA approved FDA approved.

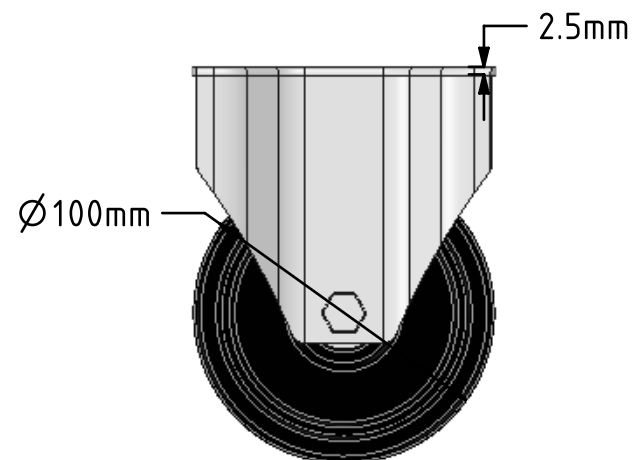
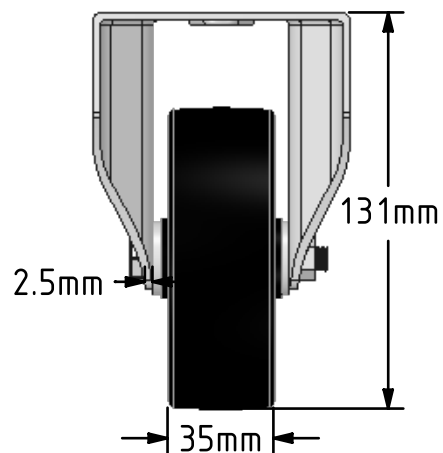
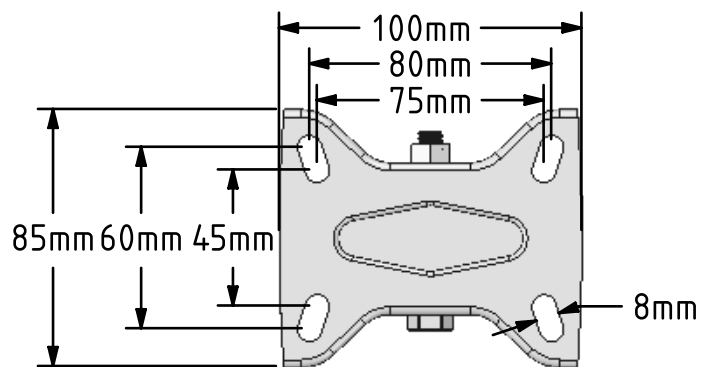

	NAME	DATE
DRAWN	Matt	09/03/18
APPROVED BY	Chris	09/03/18
SCALE	2:5	09/03/18
WEIGHT	0.652kg	09/03/18

 BIL Group Ltd, Porte Marsh Road, Calne
 Wiltshire, SN11 9BW, United Kingdom
 Tel +44 (0)1249 822 222 Fax: +44 (0)1249 822 300
 www.bilgroup.co.uk

TITLE		REV
BZMHF100LAN3		1
SIZE	DWG NO.	
A4	BILCW03BZMHF100LAN3_01	
FILE NAME	SHEET 1 OF 1	
	BILCW03BZMHF100LAN3_01.PDF	

UNLESS OTHERWISE SPECIFIED DIMENSIONS ARE IN MILLIMETRES
 Unspecified Tolerances
 Machining ± 0.25mm
 Fabrication ± 1mm