

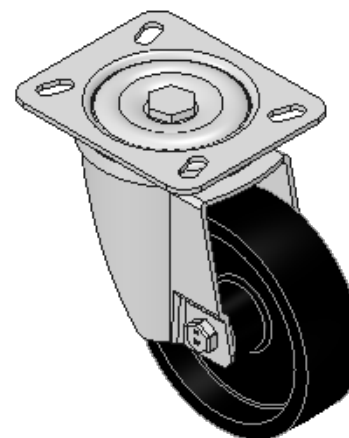

DRAWING DISCLAIMER  
 COPYRIGHT OF THIS DRAWING IS RESERVED BY BIL GROUP LTD. IT IS ISSUED ON CONDITION THAT IT IS NOT REPRODUCED, COPIED, OR DISCLOSED TO A THIRD PARTY EITHER WHOLLY OR IN PART WITHOUT THE CONSENT IN WRITING OF BIL GROUP LTD.

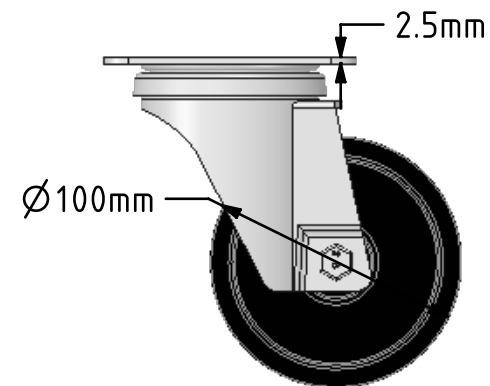
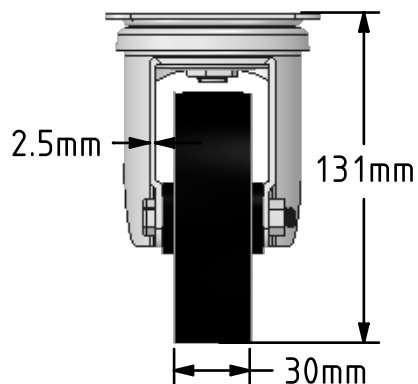
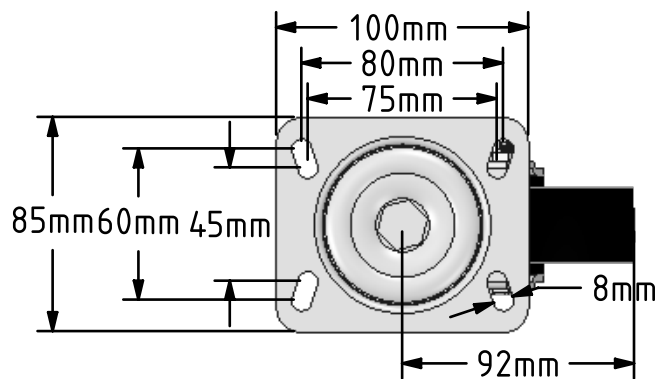

**Description:**  
 BZMH100TP3

Pressed steel swivel castor with a top plate fixing fitted with a 300c black thermoplastic wheel with a plain bore. Wheel diameter 100mm, tread width 35mm, overall height 133mm, top plate 100mm x 85mm, hole centres 80mm x 60mm ore 75mm x 45mm. Load capacity 200kg at 300c.



	NAME	DATE	 BIL Group Ltd, Porte Marsh Road, Calne Wiltshire, SN11 9BW, United Kingdom Tel +44 (0)1249 822 222 Fax: +44 (0)1249 822 300 www.bilgroup.co.uk	
DRAWN	Matt	12/03/18	TITLE	
APPROVED BY	Chris	12/03/18	BZMH100TP3	
SCALE	1:3	12/03/18	SIZE	DWG NO.
WEIGHT	0.873kg	12/03/18	A4	BILCW03BZMH100TP3_01
UNLESS OTHERWISE SPECIFIED DIMENSIONS ARE IN MILLIMETRES			REV	1
Unspecified Tolerances Machining ± 0.25mm Fabrication ± 1mm			FILE NAME	BILCW03BZMH100TP3_01.PDF SHEET 1 OF 1