

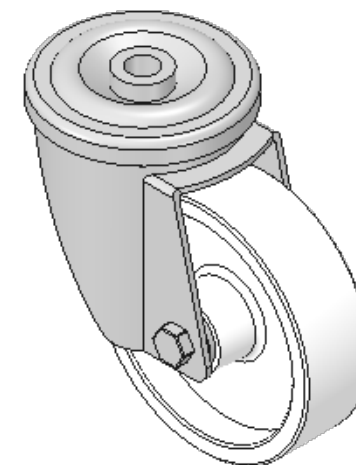

DRAWING DISCLAIMER
 COPYRIGHT OF THIS DRAWING IS RESERVED BY BIL GROUP LTD. IT IS ISSUED ON CONDITION THAT IT IS NOT REPRODUCED, COPIED, OR DISCLOSED TO A THIRD PARTY EITHER WHOLLY OR IN PART WITHOUT THE CONSENT IN WRITING OF BIL GROUP LTD.

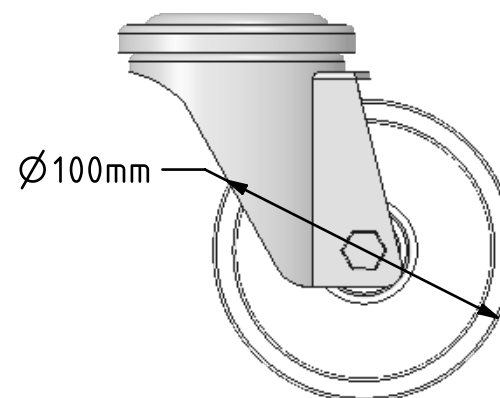
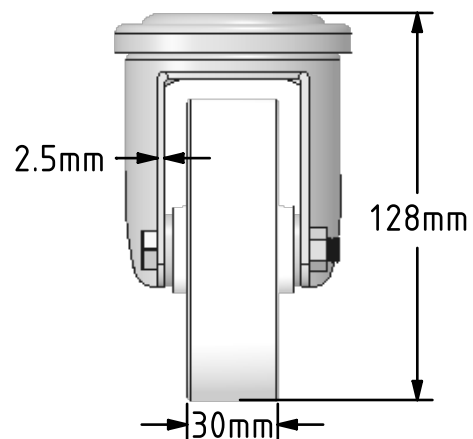
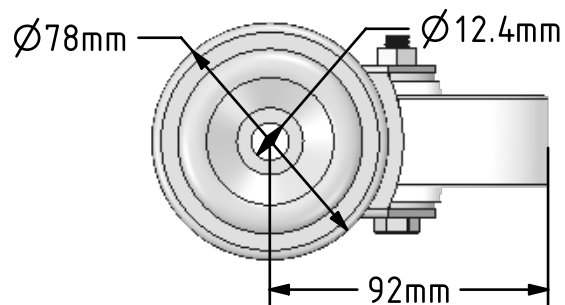

Description:
 BZMH100NYBH12HT

Pressed steel swivel castor with a 12mm bolt hole fitted with a high temp off white nylon wheel with plain bearing. Wheel diameter 100mm, tread width 30mm, overall height 128mm, Load capacity 200kg at a maximum 150 c.



	NAME	DATE	BIL Group Ltd, Porte Marsh Road, Calne Wiltshire, SN11 9BW, United Kingdom Tel +44 (0)1249 822 222 Fax: +44 (0)1249 822 300 www.bilgroup.co.uk	
DRAWN	Matt	21/03/18		
APPROVED BY	Tim W	21/03/18		
SCALE	2:5	21/03/18		
WEIGHT	0.706kg	21/03/18		
UNLESS OTHERWISE SPECIFIED DIMENSIONS ARE IN MILLIMETRES			TITLE	
Unspecified Tolerances Machining ± 0.25mm Fabrication ± 1mm			BZMH100NYBH12HT	
SIZE A4		DWG NO. BILCW03BZMH100NYBH12HT_01	REV 1	
FILE NAME BILCW03BZMH100NYBH12HT_01.PDF			SHEET 1 OF 1	