

DRAWING DISCLAIMER
 COPYRIGHT OF THIS DRAWING IS RESERVED BY BIL GROUP LTD. IT IS ISSUED ON CONDITION THAT IT IS NOT REPRODUCED, COPIED, OR DISCLOSED TO A THIRD PARTY EITHER WHOLLY OR IN PART WITHOUT THE CONSENT IN WRITING OF BIL GROUP LTD.

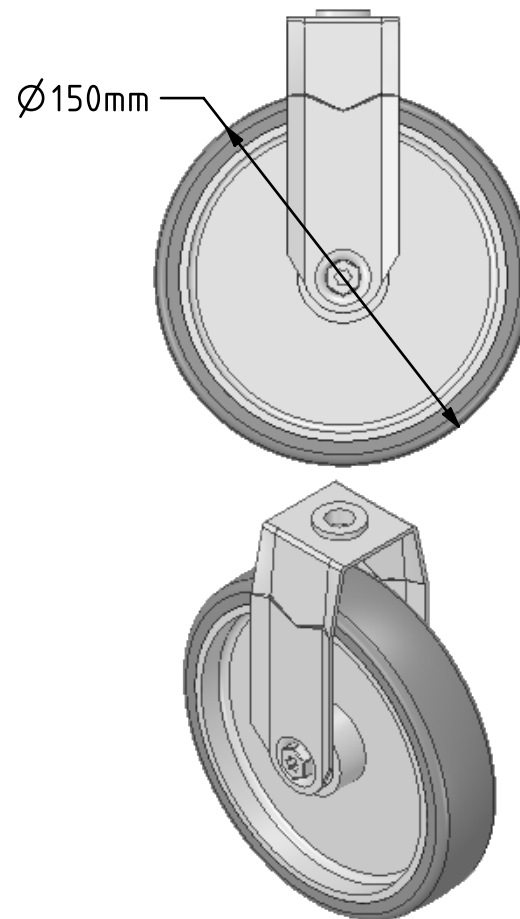

Description:
 BZMF150VGRBJBH12

Pressed steel fixed castor with a 12mm bolt hole fitted with a grey thermoplastic rubber tyre on polypropylene centred wheel with ball bearings. Wheel diameter 150mm, tread width 32mm, overall height 181mm, Load capacity 100kg.

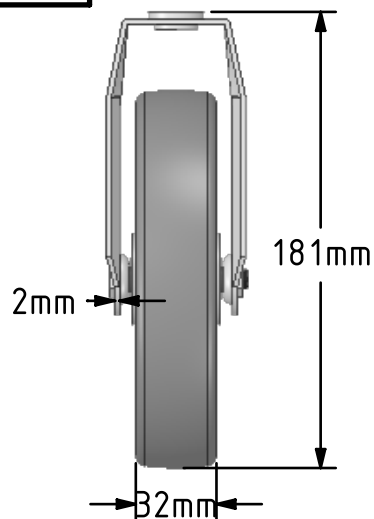
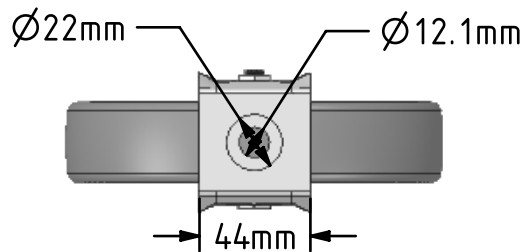

	NAME	DATE
DRAWN	Matt	11/03/19
APPROVED BY	Chris	11/03/19
SCALE	1:3	11/03/19
WEIGHT	0.565kg	11/03/19

 BIL Group Ltd, Porte Marsh Road, Calne
 Wiltshire, SN11 9BW, United Kingdom
 Tel +44 (0)1249 822 222 Fax: +44 (0)1249 822 300
 www.bilgroup.co.uk

TITLE		
BZMF150VGRBJBH12		
SIZE	DWG NO.	REV
A4	BILCW03BZMF150VGRBJBH12__01	1
FILE NAME BILCW03BZMF150VGRBJBH12__01.PDF SHEET 1 OF 1		

UNLESS OTHERWISE SPECIFIED DIMENSIONS ARE IN MILLIMETRES
 Unspecified Tolerances
 Machining ± 0.25mm
 Fabrication ± 1mm