

DRAWING DISCLAIMER
 COPYRIGHT OF THIS DRAWING IS RESERVED BY BIL GROUP LTD. IT IS ISSUED ON CONDITION THAT IT IS NOT REPRODUCED, COPIED, OR DISCLOSED TO A THIRD PARTY EITHER WHOLLY OR IN PART WITHOUT THE CONSENT IN WRITING OF BIL GROUP LTD.

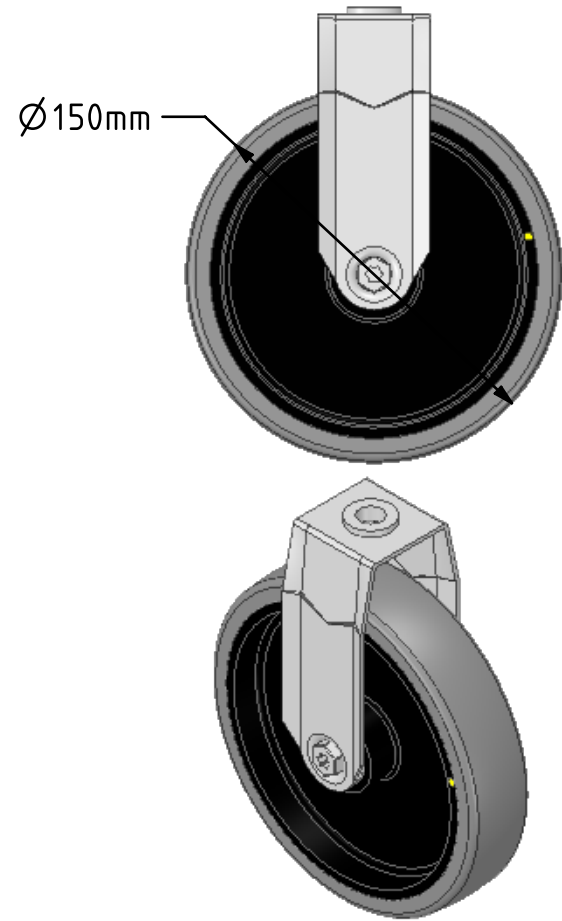

Description:
 BZMF150GRECBJBH12
 Pressed steel fixed castor with a 12mm bolt hole fitted with a grey electrically conductive rubber on grey polypropylene centred wheel with ball bearings, Wheel diameter 150mm, 32mm tread width, 181mm overall height, with a load capacity of 100kgs. Conductive offers a resistance $R < 10K\Omega$

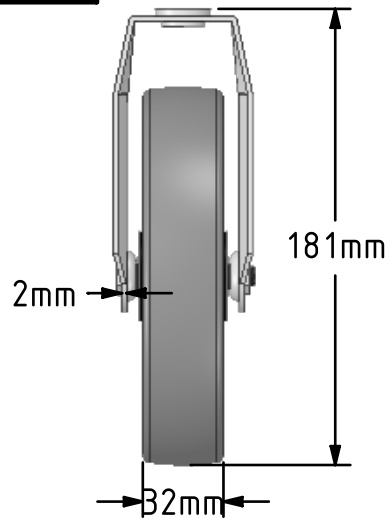
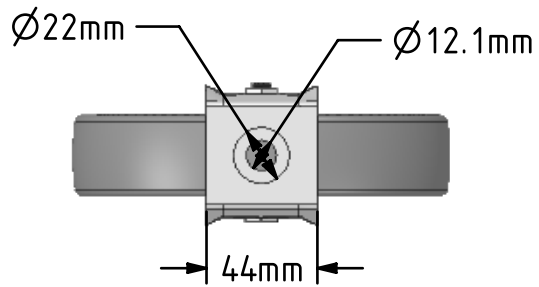

	NAME	DATE
DRAWN	Matt	12/03/19
APPROVED BY	Chris	12/03/19
SCALE	1:3	12/03/19
WEIGHT	0.584kg	12/03/19

BIL Group Ltd, Porte Marsh Road, Calne
 Wiltshire, SN11 9BW, United Kingdom
 Tel +44 (0)1249 822 222 Fax: +44 (0)1249 822 300
 www.bilgroup.co.uk

TITLE
BZMF150GRECBJBH12

UNLESS OTHERWISE SPECIFIED DIMENSIONS ARE IN MILLIMETRES
 Unspecified Tolerances
 Machining $\pm 0.25\text{mm}$
 Fabrication $\pm 1\text{mm}$

SIZE	DWG NO.	REV
A4	BILCW03BZMF150GRECBJBH12__01	1

FILE NAME BILCW03BZMF150GRECBJBH12__01.PDF SHEET 1 OF 1