

DRAWING DISCLAIMER  
 COPYRIGHT OF THIS DRAWING IS RESERVED BY BIL GROUP LTD. IT IS ISSUED ON CONDITION THAT IT IS NOT REPRODUCED, COPIED, OR DISCLOSED TO A THIRD PARTY EITHER WHOLLY OR IN PART WITHOUT THE CONSENT IN WRITING OF BIL GROUP LTD.

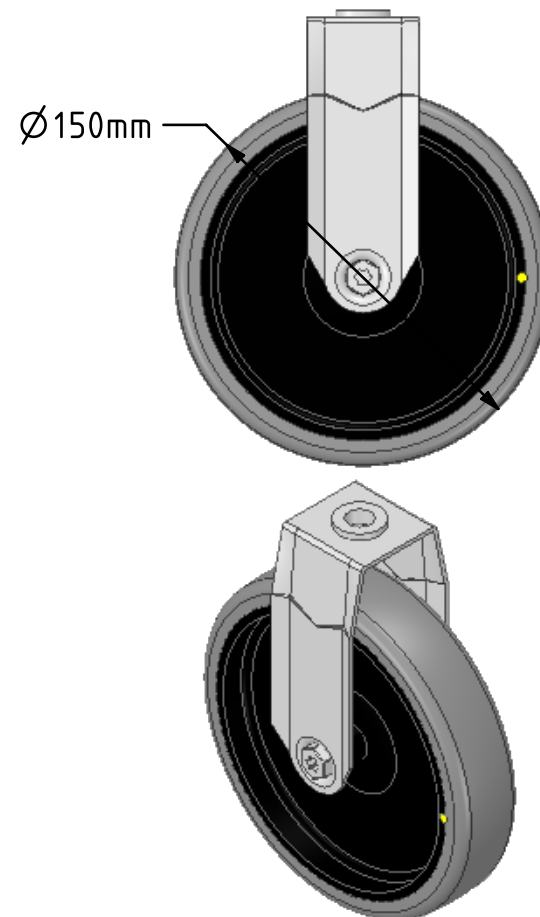

Description:  
 BZMF150GRECBH12

Pressed steel fixed castor with a 12mm bolt hole fitted with a grey electrically conductive rubber on grey polypropylene centred wheel with a plain bore, Wheel diameter 150mm, 32mm tread width, 181mm overall height, with a load capacity of 100kgs. Conductive offers a resistance  $R < 10K\Omega$

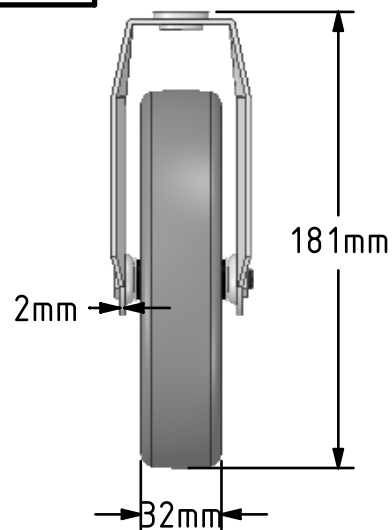
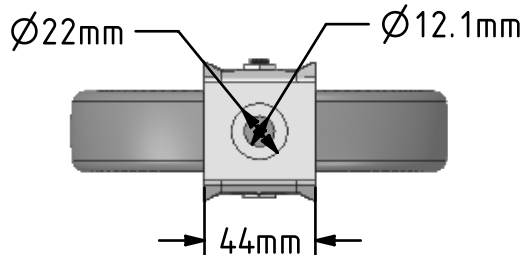

	NAME	DATE
DRAWN	Matt	12/03/19
APPROVED BY	Chris	12/03/19
SCALE	1:3	12/03/19
WEIGHT	0.5kg	12/03/19

UNLESS OTHERWISE SPECIFIED DIMENSIONS ARE IN MILLIMETRES

Unspecified Tolerances  
 Machining  $\pm 0.25\text{mm}$   
 Fabrication  $\pm 1\text{mm}$



BIL Group Ltd, Porte Marsh Road, Calne  
 Wiltshire, SN11 9BW, United Kingdom  
 Tel +44 (0)1249 822 222 Fax: +44 (0)1249 822 300  
 www.bilgroup.co.uk

TITLE

BZMF150GRECBH12

SIZE	DWG NO.	REV
A4	BILCW03BZMF150GRECBH12_01	1

FILE NAME BILCW03BZMF150GRECBH12\_01.PDF SHEET 1 OF 1