

DRAWING DISCLAIMER
 COPYRIGHT OF THIS DRAWING IS RESERVED BY BIL GROUP LTD. IT IS ISSUED ON CONDITION THAT IT IS NOT REPRODUCED, COPIED, OR DISCLOSED TO A THIRD PARTY EITHER WHOLLY OR IN PART WITHOUT THE CONSENT IN WRITING OF BIL GROUP LTD.

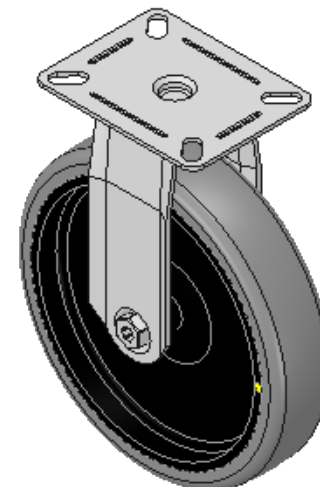

Description:
 BZMF150GREC

Pressed steel fixed castor with a top plate fitted with a grey electrically conductive rubber on grey polypropylene centred wheel with a plain bore. Wheel diameter 150mm, 32mm tread width, 181mm overall height, 90mm x 70mm top plate, 75mm x 56mm or 64mm x 44mm bolt holes, with a load capacity of 100kgs. Conductive offers a resistance R<10KΩ

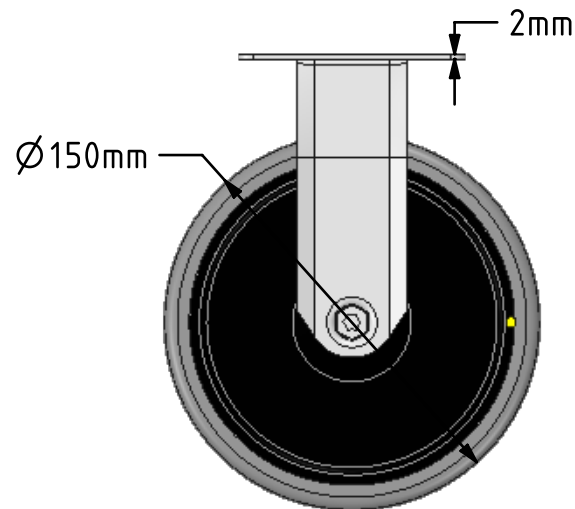
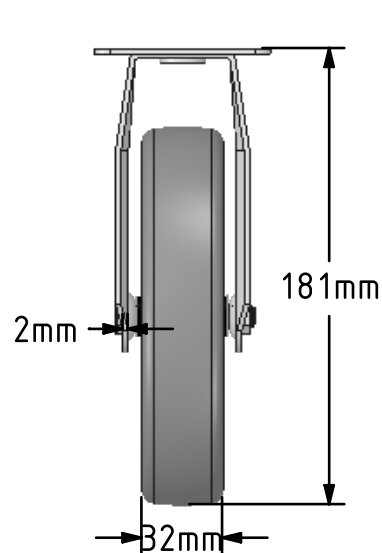
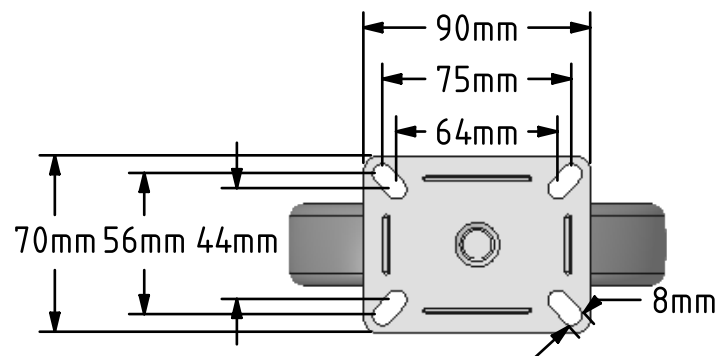

	NAME	DATE
DRAWN	Matt	20/06/18
APPROVED BY	Chris	20/06/18
SCALE	1:3	20/06/18
WEIGHT	0.604kg	20/06/18

UNLESS OTHERWISE SPECIFIED DIMENSIONS ARE IN MILLIMETRES

Unspecified Tolerances
 Machining ± 0.25mm
 Fabrication ± 1mm



BIL Group Ltd, Porte Marsh Road, Calne
 Wiltshire, SN11 9BW, United Kingdom
 Tel +44 (0)1249 822 222 Fax: +44 (0)1249 822 300
 www.bilgroup.co.uk

TITLE

BZMF150GREC

SIZE DWG NO.
 A4 BILCW03BZMF150GREC_01

REV
 1

FILE NAME BILCW03BZMF150GREC_01.PDF SHEET 1 OF 1