

DRAWING DISCLAIMER
 COPYRIGHT OF THIS DRAWING IS RESERVED BY BIL GROUP LTD. IT IS ISSUED ON CONDITION THAT IT IS NOT REPRODUCED, COPIED, OR DISCLOSED TO A THIRD PARTY EITHER WHOLLY OR IN PART WITHOUT THE CONSENT IN WRITING OF BIL GROUP LTD.

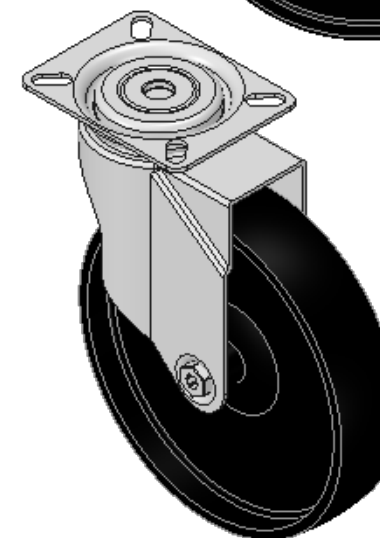

Description:
 BZM150PL

Pressed steel swivel castor with a top plate fixing fitted with a black polypropylene wheel with plain bore. Wheel diameter 150mm, tread width 32mm, overall height 181mm, top plate 90mm x 70mm, hole centres 75mm x 56mm or 64mm x 44mm. Load capacity 100kg.

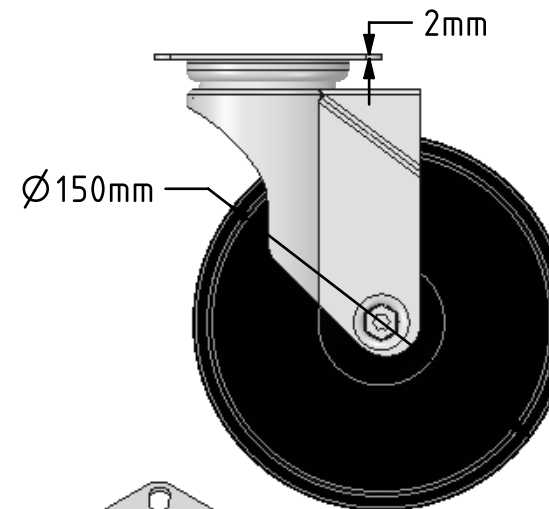
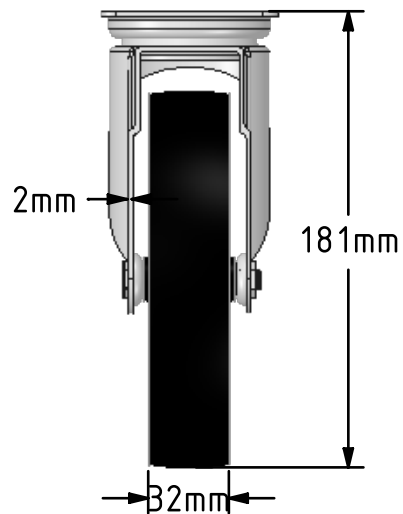
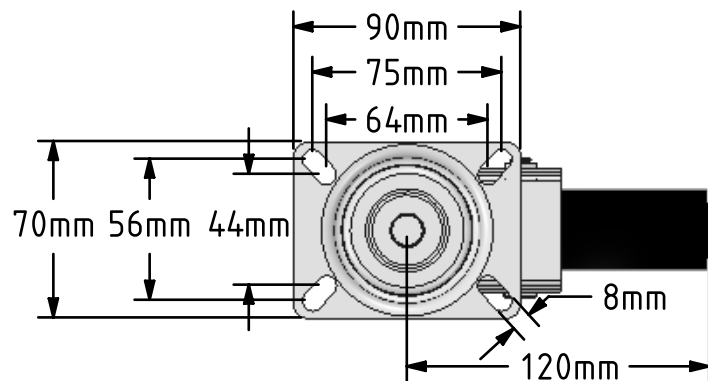

| | NAME | DATE |
|-------------|---------|----------|
| DRAWN | Matt | 18/06/18 |
| APPROVED BY | Chris | 18/06/18 |
| SCALE | 1:3 | 18/06/18 |
| WEIGHT | 0.628kg | 18/06/18 |

UNLESS OTHERWISE SPECIFIED DIMENSIONS ARE IN MILLIMETRES

Unspecified Tolerances
 Machining ± 0.25mm
 Fabrication ± 1mm



BIL Group Ltd, Porte Marsh Road, Calne
 Wiltshire, SN11 9BW, United Kingdom
 Tel +44 (0)1249 822 222 Fax: +44 (0)1249 822 300
 www.bilgroup.co.uk

TITLE

BZM150PL

SIZE DWG NO.

A4

BILCW03BZM150PL__01

REV

1

FILE NAME

BILCW03BZM150PL__01.PDF

SHEET 1 OF 1