

DRAWING DISCLAIMER  
 COPYRIGHT OF THIS DRAWING IS RESERVED BY BIL GROUP LTD. IT IS ISSUED ON CONDITION THAT IT IS NOT REPRODUCED, COPIED, OR DISCLOSED TO A THIRD PARTY EITHER WHOLLY OR IN PART WITHOUT THE CONSENT IN WRITING OF BIL GROUP LTD.

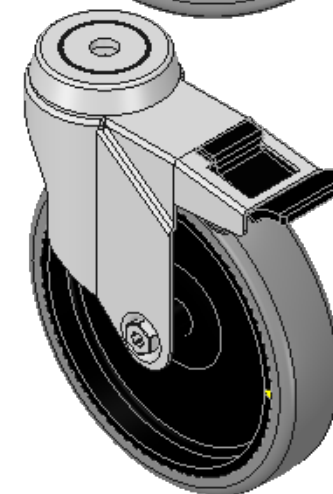

Description:  
 BZM150GRECBH12SWB

Pressed steel swivel castor with a 12mm bolt hole fitted with a grey electrically conductive rubber on grey polypropylene centred wheel and a total lock brake, Wheel diameter 150mm, 32mm tread width, 181mm overall height, load capacity 100kgs. Conductive offers a resistance  $R < 10K\Omega$

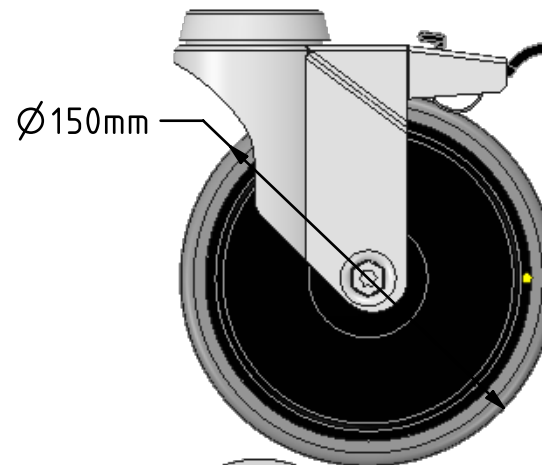
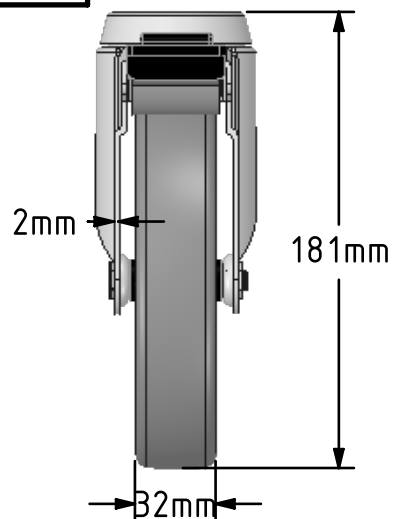
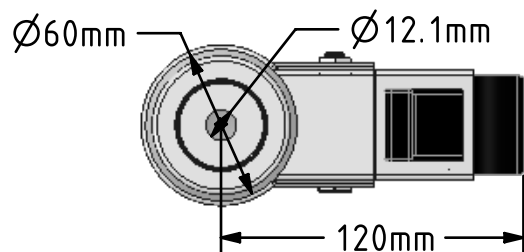

	NAME	DATE
DRAWN	Matt	22/06/18
APPROVED BY	Chris	22/06/18
SCALE	1:3	22/06/18
WEIGHT	0.717kg	22/06/18

 BIL Group Ltd, Porte Marsh Road, Calne  
 Wiltshire, SN11 9BW, United Kingdom  
 Tel +44 (0)1249 822 222 Fax: +44 (0)1249 822 300  
 www.bilgroup.co.uk

TITLE  
**BZM150GRECBH12SWB**

UNLESS OTHERWISE SPECIFIED DIMENSIONS ARE IN MILLIMETRES  
 Unspecified Tolerances  
 Machining  $\pm 0.25\text{mm}$   
 Fabrication  $\pm 1\text{mm}$

SIZE	DWG NO.	REV
A4	BILCW03BZM150GRECBH12SWB_01	1

FILE NAME BILCW03BZM150GRECBH12SWB\_01.PDF SHEET 1 OF 1