

DRAWING DISCLAIMER
 COPYRIGHT OF THIS DRAWING IS RESERVED BY BIL GROUP LTD. IT IS ISSUED ON CONDITION THAT IT IS NOT REPRODUCED, COPIED, OR DISCLOSED TO A THIRD PARTY EITHER WHOLLY OR IN PART WITHOUT THE CONSENT IN WRITING OF BIL GROUP LTD.

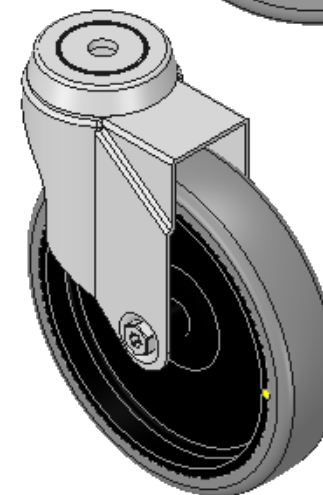

Description:
 BZM150GRECBH12

Pressed steel swivel castor with a 12mm bolt hole fitted with a grey electrically conductive rubber on grey polypropylene centred wheel, Wheel diameter 150mm, 32mm tread width, 181mm overall height, load capacity 100kgs. Conductive offers a resistance $R < 10K\Omega$

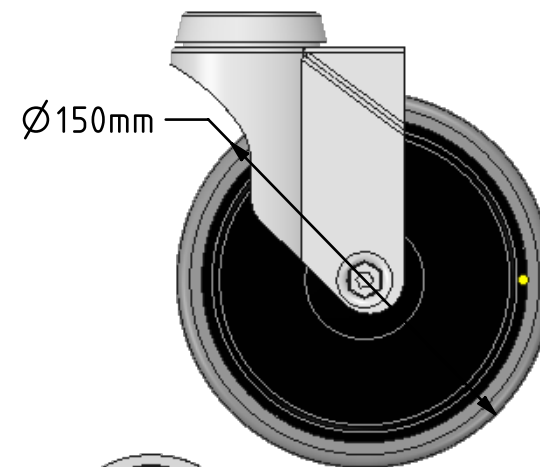
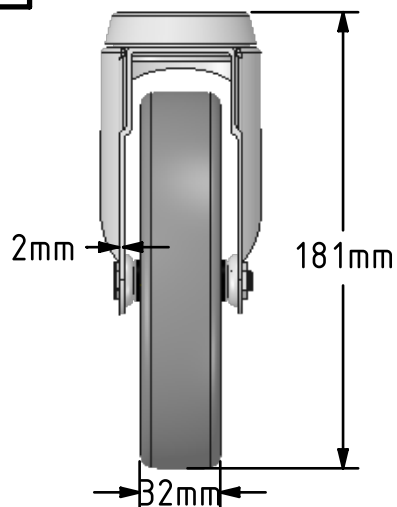
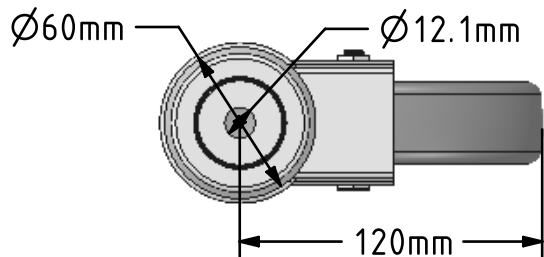

	NAME	DATE
DRAWN	Matt	22/06/18
APPROVED BY	Chris	22/06/18
SCALE	1:3	22/06/18
WEIGHT	0.662kg	22/06/18

UNLESS OTHERWISE SPECIFIED DIMENSIONS ARE IN MILLIMETRES

Unspecified Tolerances
 Machining $\pm 0.25\text{mm}$
 Fabrication $\pm 1\text{mm}$



BIL Group Ltd, Porte Marsh Road, Calne
 Wiltshire, SN11 9BW, United Kingdom
 Tel +44 (0)1249 822 222 Fax: +44 (0)1249 822 300
 www.bilgroup.co.uk

TITLE

BZM150GRECBH12

SIZE DWG NO.

A4

BILCW03BZM150GRECBH12_01

REV

1

FILE NAME BILCW03BZM150GRECBH12_01.PDF SHEET 1 OF 1