

DRAWING DISCLAIMER
 COPYRIGHT OF THIS DRAWING IS RESERVED BY BIL GROUP LTD. IT IS ISSUED ON CONDITION THAT IT IS NOT REPRODUCED, COPIED, OR DISCLOSED TO A THIRD PARTY EITHER WHOLLY OR IN PART WITHOUT THE CONSENT IN WRITING OF BIL GROUP LTD.

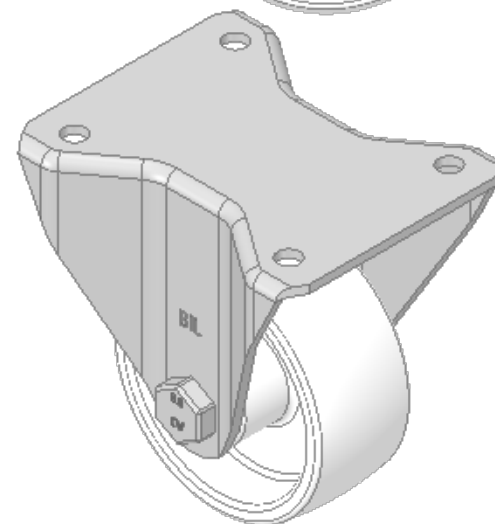

Description:
 BZHF80NYB

Pressed steel fixed castor with a top plate fixing fitted with a white nylon wheel with a roller bearing. Wheel diameter 80mm, tread width 35mm, overall height 110mm, plate size 105mm x 86mm, hole centres 80mm x 60mm. Load capacity 250kg.

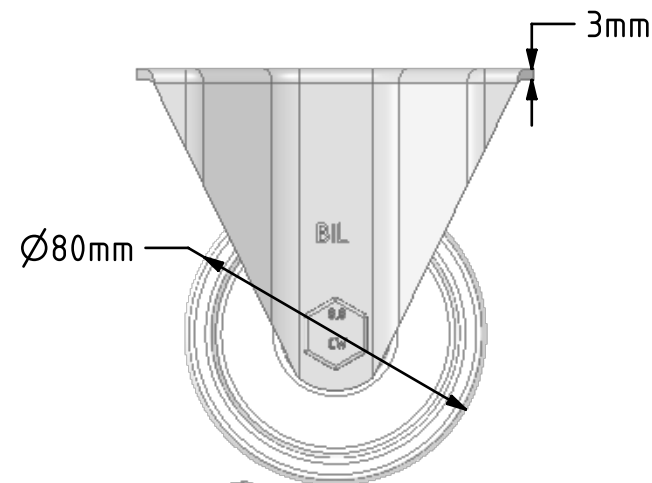
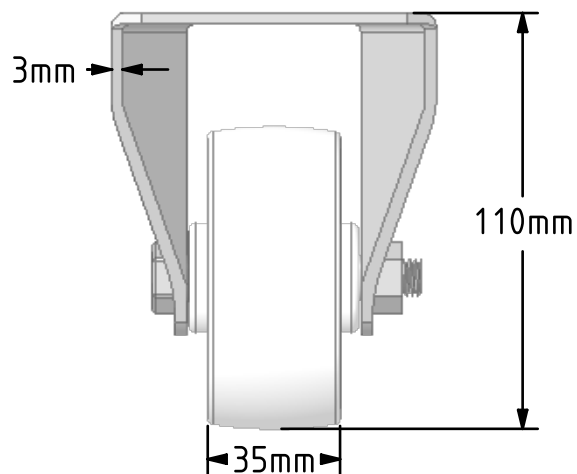
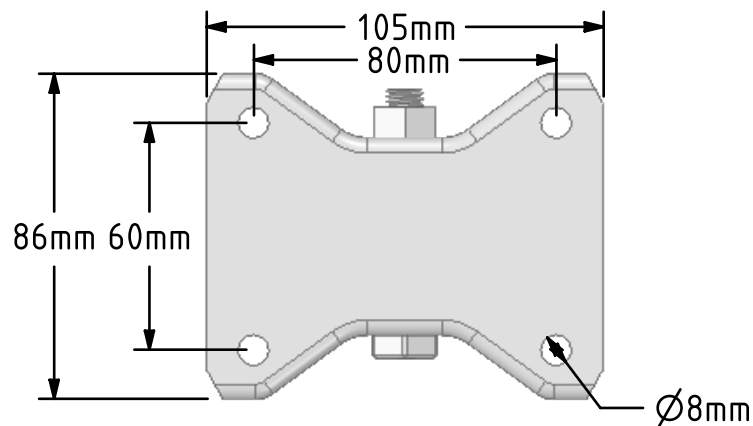

	NAME	DATE
DRAWN	Matt	15/10/18
APPROVED BY	Chris	15/10/18
SCALE	1:2	15/10/18
WEIGHT	0.551kg	15/10/18

UNLESS OTHERWISE SPECIFIED DIMENSIONS ARE IN MILLIMETRES

Unspecified Tolerances
 Machining ± 0.25mm
 Fabrication ± 1mm



BIL Group Ltd, Porte Marsh Road, Calne
 Wiltshire, SN11 9BW, United Kingdom
 Tel +44 (0)1249 822 222 Fax: +44 (0)1249 822 300
 www.bilgroup.co.uk

TITLE

BZHF80NYB

SIZE A4 DWG NO.

BILCW03BZHF80NYB_01

REV 1

FILE NAME BILCW03BZHF80NYB_01.PDF

SHEET 1 OF 1