

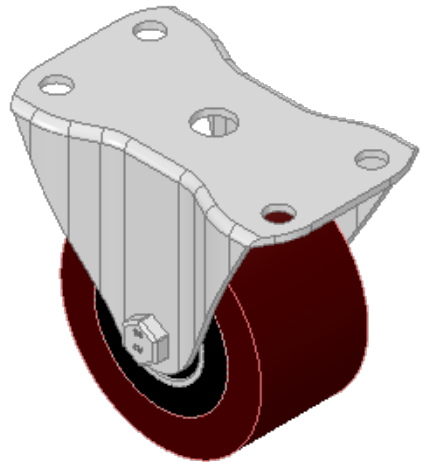

DRAWING DISCLAIMER
 COPYRIGHT OF THIS DRAWING IS RESERVED BY BIL GROUP LTD. IT IS ISSUED ON CONDITION THAT IT IS NOT REPRODUCED, COPIED, OR DISCLOSED TO A THIRD PARTY EITHER WHOLLY OR IN PART WITHOUT THE CONSENT IN WRITING OF BIL GROUP LTD.

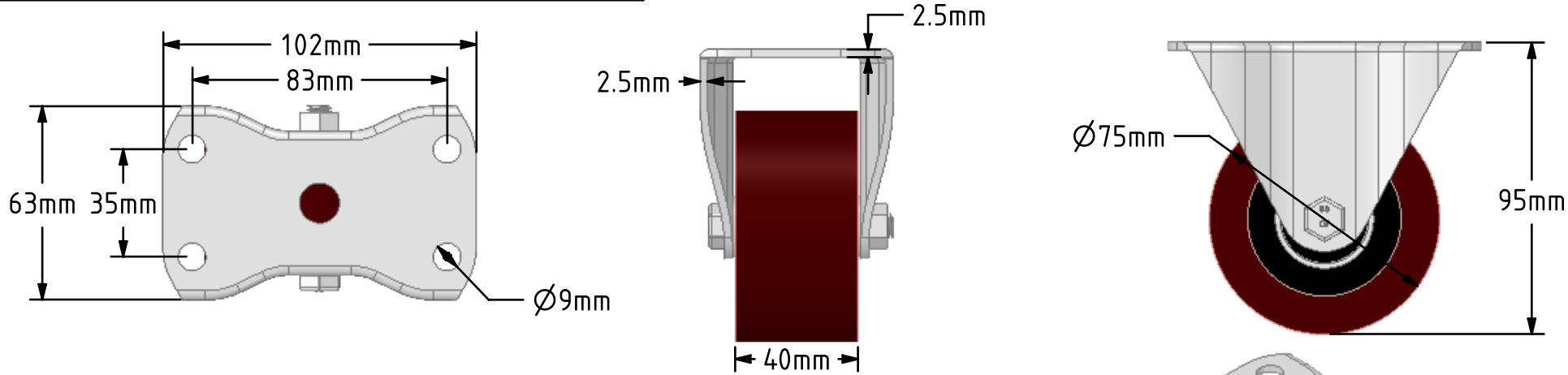

Description:
BZHF75PTBJ
 Pressed steel fixed castor with a top plate fixing fitted with a polyurethane wheel on a cast iron centre with ball bearings. Wheel diameter 75mm, tread width 40mm, overall height 95mm, top plate 102mm x 63mm, hole centres 83mm x 35mm. Load capacity 125kg.

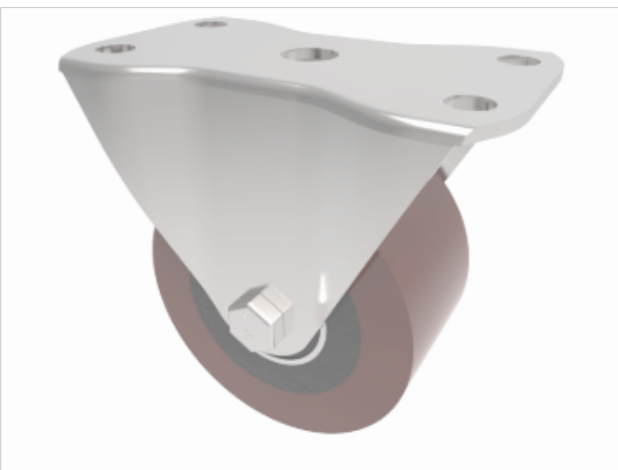

	NAME	DATE	 BIL Group Ltd, Porte Marsh Road, Calne Wiltshire, SN11 9BW, United Kingdom Tel +44 (0)1249 822 222 Fax: +44 (0)1249 822 300 www.bilgroup.co.uk
DRAWN	Matt	21/09/18	
APPROVED BY	Chris	21/09/18	
SCALE	1:2	21/09/18	
WEIGHT	0.817kg	21/09/18	TITLE
UNLESS OTHERWISE SPECIFIED DIMENSIONS ARE IN MILLIMETRES Unspecified Tolerances Machining ± 0.25mm Fabrication ± 1mm			BZHF75PTBJ
SIZE		DWG NO.	REV
A4		BILCW03BZHF75PTBJ_01	1
FILE NAME		SHEET 1 OF 1	
BILCW03BZHF75PTBJ_01.PDF			