

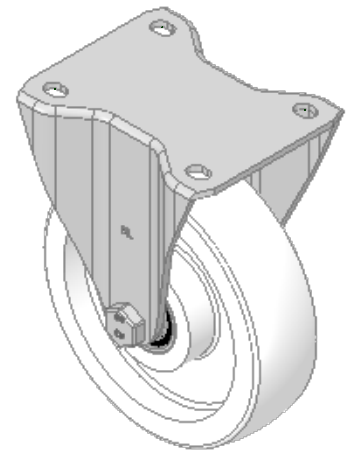

DRAWING DISCLAIMER
 COPYRIGHT OF THIS DRAWING IS RESERVED BY BIL GROUP LTD. IT IS ISSUED ON CONDITION THAT IT IS NOT REPRODUCED, COPIED, OR DISCLOSED TO A THIRD PARTY EITHER WHOLLY OR IN PART WITHOUT THE CONSENT IN WRITING OF BIL GROUP LTD.

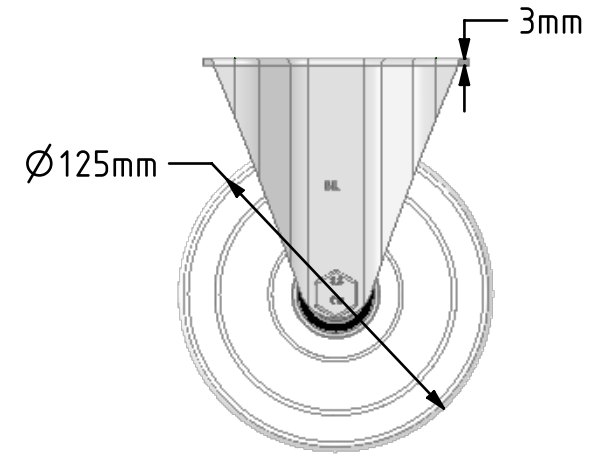

Description:
 BZHF125NYBJ
 Pressed steel fixed castor with a top plate fixing fitted with a white nylon wheel with ball bearings. Wheel diameter 125mm, tread width 35mm, overall height 156mm, top plate 105mm x 86mm, hole centres 80mm x 60mm. Load capacity 500kg.

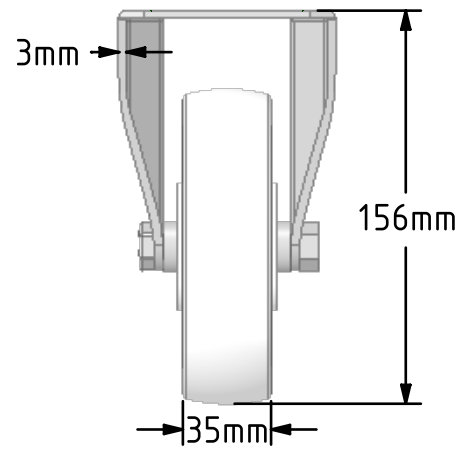
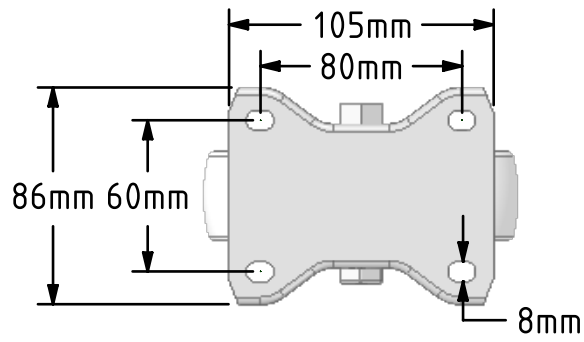

	NAME	DATE	 BIL Group Ltd, Porte Marsh Road, Calne Wiltshire, SN11 9BW, United Kingdom Tel +44 (0)1249 822 222 Fax: +44 (0)1249 822 300 www.bilgroup.co.uk
DRAWN	Matt	15/10/18	
APPROVED BY	Chris	15/10/18	
SCALE	1:3	15/10/18	
WEIGHT	0.896kg	15/10/18	
UNLESS OTHERWISE SPECIFIED DIMENSIONS ARE IN MILLIMETRES Unspecified Tolerances Machining ± 0.25mm Fabrication ± 1mm			TITLE BZHF125NYBJ
SIZE	DWG NO.		REV
A4	BILCW03BZHF125NYBJ_01		1
FILE NAME	BILCW03BZHF125NYBJ_01.PDF		SHEET 1 OF 1