

DRAWING DISCLAIMER
 COPYRIGHT OF THIS DRAWING IS RESERVED BY BIL GROUP LTD. IT IS ISSUED ON CONDITION THAT IT IS NOT REPRODUCED, COPIED, OR DISCLOSED TO A THIRD PARTY EITHER WHOLLY OR IN PART WITHOUT THE CONSENT IN WRITING OF BIL GROUP LTD.

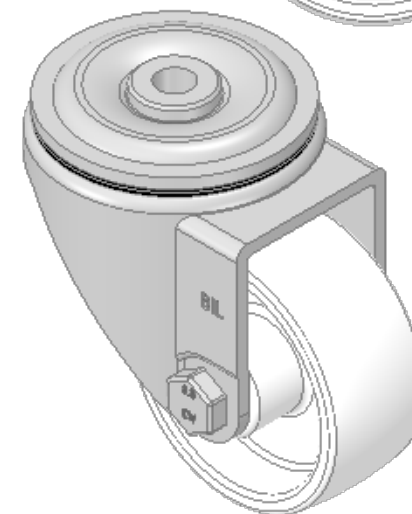

Description:
 BZH80NYBBH12

Pressed steel swivel castor with a 12mm bolt hole fitted with a white nylon wheel with a roller bearing. Wheel diameter 80mm, tread width 35mm, overall height 110mm. Load capacity 250kg.

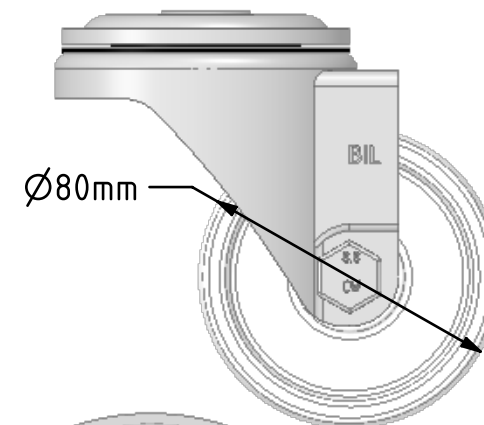
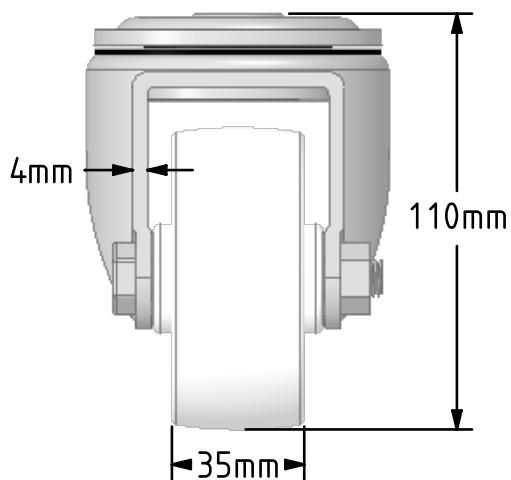
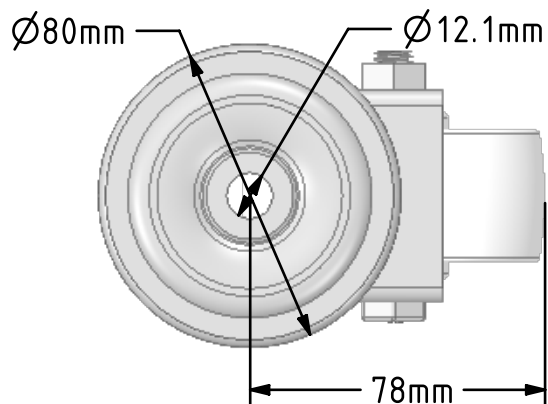

	NAME	DATE
DRAWN	Matt	22/10/18
APPROVED BY	Chris	22/10/18
SCALE	1:2	22/10/18
WEIGHT	0.77kg	22/10/18

UNLESS OTHERWISE SPECIFIED DIMENSIONS ARE IN MILLIMETRES

Unspecified Tolerances
 Machining ± 0.25mm
 Fabrication ± 1mm



BIL Group Ltd, Porte Marsh Road, Calne
 Wiltshire, SN11 9BW, United Kingdom
 Tel +44 (0)1249 822 222 Fax: +44 (0)1249 822 300
 www.bilgroup.co.uk

TITLE

BZH80NYBBH12

SIZE	DWG NO.	REV
A4	BILCW03BZH80NYBBH12_01	1

FILE NAME BILCW03BZH80NYBBH12_01.PDF SHEET 1 OF 1