

DRAWING DISCLAIMER  
 COPYRIGHT OF THIS DRAWING IS RESERVED BY BIL GROUP LTD. IT IS ISSUED ON CONDITION THAT IT IS NOT REPRODUCED, COPIED, OR DISCLOSED TO A THIRD PARTY EITHER WHOLLY OR IN PART WITHOUT THE CONSENT IN WRITING OF BIL GROUP LTD.

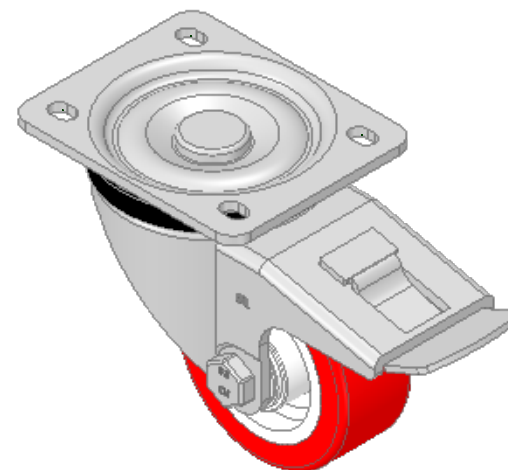

Description:  
 BZH80NPBSWB

Pressed steel swivel castor with a top plate fixing fitted with a red polyurethane tyre on white nylon centred wheel with a roller bearing and a total lock brake. Wheel diameter 80mm, tread width 33mm, overall height 110mm, top plate 105mm x 86mm, hole centres 80mm x 60mm. Load capacity 210kg.

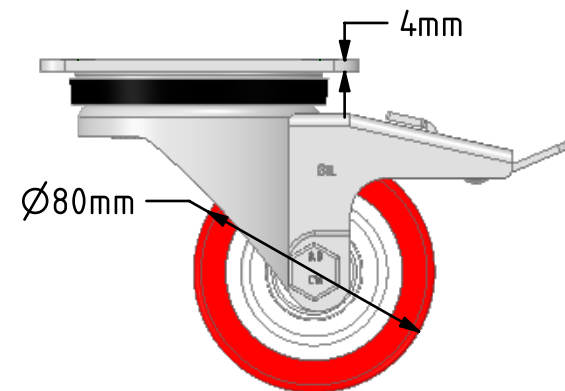
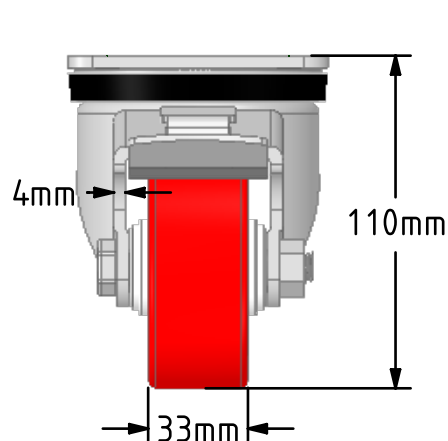
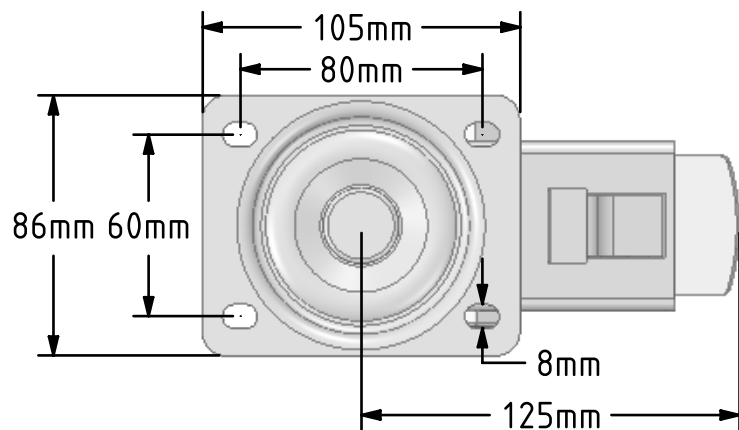

	NAME	DATE
DRAWN	Matt	19/10/18
APPROVED BY	Chris	19/10/18
SCALE	2:5	19/10/18
WEIGHT	1.186kg	19/10/18

UNLESS OTHERWISE SPECIFIED DIMENSIONS ARE IN MILLIMETRES

Unspecified Tolerances  
 Machining ± 0.25mm  
 Fabrication ± 1mm



BIL Group Ltd, Porte Marsh Road, Calne  
 Wiltshire, SN11 9BW, United Kingdom  
 Tel +44 (0)1249 822 222 Fax: +44 (0)1249 822 300  
 www.bilgroup.co.uk

TITLE

BZH80NPBSWB

SIZE DWG NO.

A4

BILCW03BZH80NPBSWB\_01

REV

1

FILE NAME BILCW03BZH80NPBSWB\_01.PDF

SHEET 1 OF 1