

DRAWING DISCLAIMER
 COPYRIGHT OF THIS DRAWING IS RESERVED BY BIL GROUP LTD. IT IS ISSUED ON CONDITION THAT IT IS NOT REPRODUCED, COPIED, OR DISCLOSED TO A THIRD PARTY EITHER WHOLLY OR IN PART WITHOUT THE CONSENT IN WRITING OF BIL GROUP LTD.

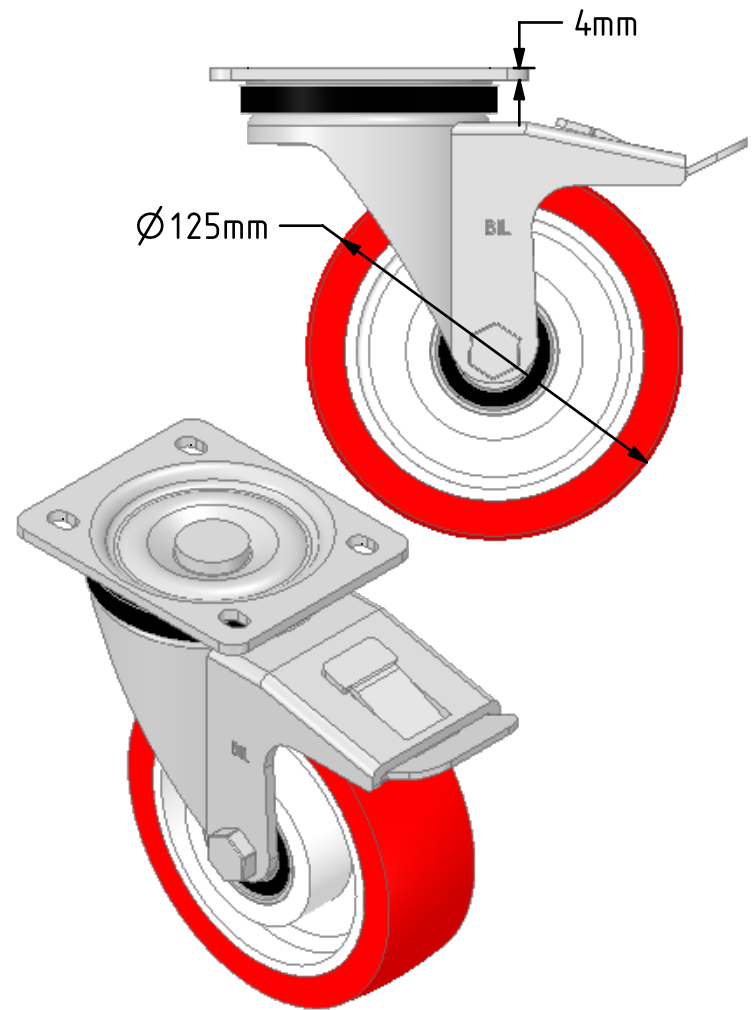

Description:
 BZH125NPBJSWB

Pressed steel swivel castor with a top plate fixing fitted with a red polyurethane tyre on a white nylon centred wheel with ball bearings and total lock brake. Wheel diameter 125mm, tread width 40mm, overall height 156mm, top plate 105mm x 86mm, hole centres 80mm x 60mm. Load capacity 350kg.

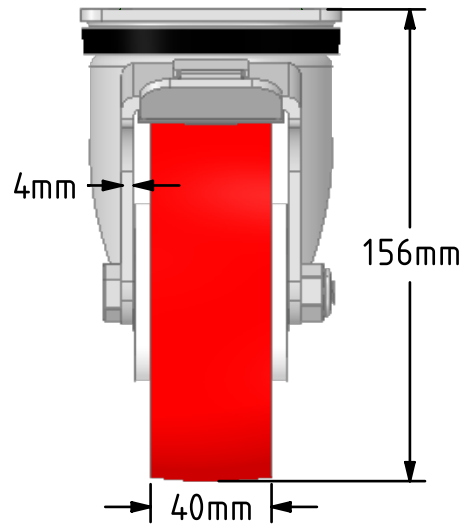
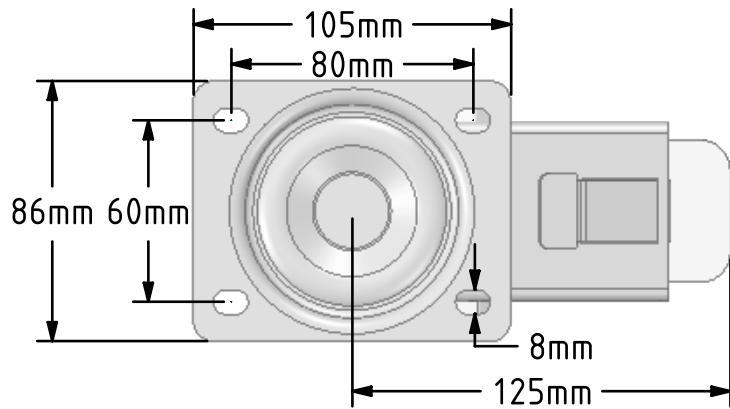

	NAME	DATE
DRAWN	Matt	18/10/18
APPROVED BY	Tim W	18/10/18
SCALE	2.5	18/10/18
WEIGHT	1.671kg	18/10/18

BIL BIL Group Ltd, Porte Marsh Road, Calne
 Wiltshire, SN11 9BW, United Kingdom
 Tel +44 (0)1249 822 222 Fax: +44 (0)1249 822 300
 www.bilgroup.co.uk

TITLE		REV
BZH125NPBJSWB		1
SIZE	DWG NO.	FILE NAME
A4	BILCW03BZH125NPBJSWB_01	BILCW03BZH125NPBJSWB_01.PDF
UNLESS OTHERWISE SPECIFIED DIMENSIONS ARE IN MILLIMETRES		SHEET 1 OF 1
Unspecified Tolerances Machining ± 0.25mm Fabrication ± 1mm		