

DRAWING DISCLAIMER
 COPYRIGHT OF THIS DRAWING IS RESERVED BY BIL GROUP LTD. IT IS ISSUED ON CONDITION THAT IT IS NOT REPRODUCED, COPIED, OR DISCLOSED TO A THIRD PARTY EITHER WHOLLY OR IN PART WITHOUT THE CONSENT IN WRITING OF BIL GROUP LTD.

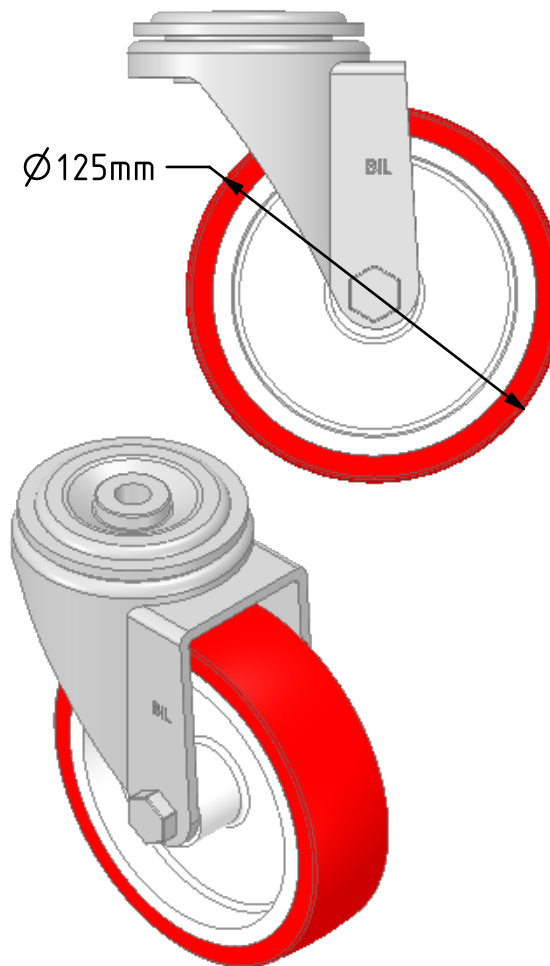

Description:
 BZH125NPBH12

Pressed steel swivel castor with a 12mm bolt hole fixing fitted with a red polyurethane tyre on white nylon centred wheel with a plain bearing. Wheel diameter 125mm, tread width 35mm, overall height 156mm. Load capacity 300kg.

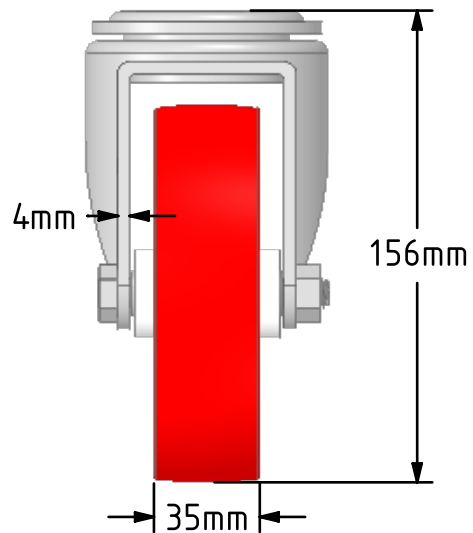
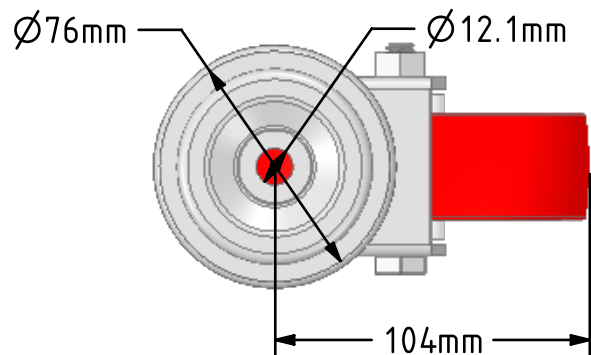

	NAME	DATE
DRAWN	Matt	30/10/18
APPROVED BY	Chris	30/10/18
SCALE	2.5	30/10/18
WEIGHT	1.022kg	30/10/18

 BIL Group Ltd, Porte Marsh Road, Calne
 Wiltshire, SN11 9BW, United Kingdom
 Tel +44 (0)1249 822 222 Fax: +44 (0)1249 822 300
 www.bilgroup.co.uk

TITLE	BZH125NPBH12	
-------	--------------	--

UNLESS OTHERWISE SPECIFIED DIMENSIONS ARE IN MILLIMETRES
 Unspecified Tolerances
 Machining ± 0.25mm
 Fabrication ± 1mm

SIZE	DWG NO.	REV
A4	BILCW03BZH125NPBH12__01	1
FILE NAME	BILCW03BZH125NPBH12__01.PDF SHEET 1 OF 1	