

DRAWING DISCLAIMER
 COPYRIGHT OF THIS DRAWING IS RESERVED BY BIL GROUP LTD. IT IS ISSUED ON CONDITION THAT IT IS NOT REPRODUCED, COPIED, OR DISCLOSED TO A THIRD PARTY EITHER WHOLLY OR IN PART WITHOUT THE CONSENT IN WRITING OF BIL GROUP LTD.

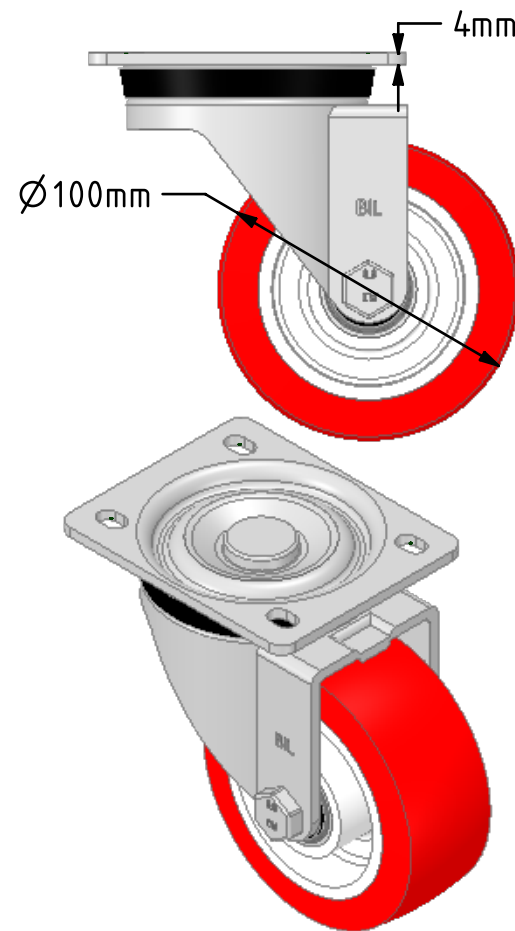

Description:
 BZH100NPBJ

Pressed steel swivel castor with a top plate fitted with a red polyurethane tyre on white nylon centred wheel with ball bearings, wheel diameter 100mm, tread width 40mm, overall height 128mm, top plate 105mm x 80mm, bolt centres 80mm x 60mm with a load capacity of 250kgs.

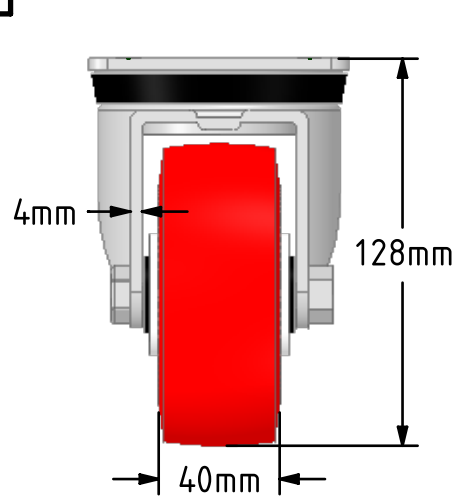
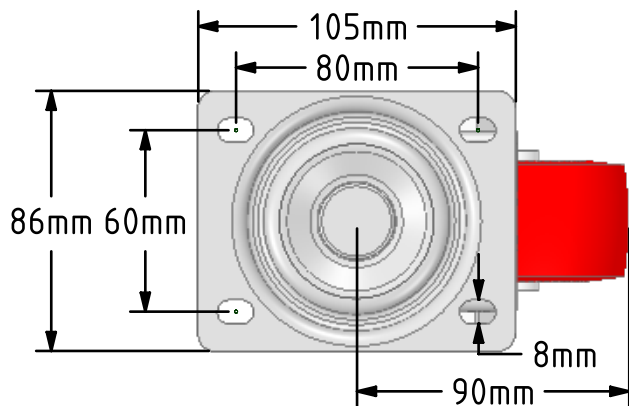

	NAME	DATE
DRAWN	Matt	19/10/18
APPROVED BY	Chris	19/10/18
SCALE	2:5	19/10/18
WEIGHT	1.149kg	19/10/18

UNLESS OTHERWISE SPECIFIED DIMENSIONS ARE IN MILLIMETRES

Unspecified Tolerances
 Machining ± 0.25mm
 Fabrication ± 1mm



BIL Group Ltd, Porte Marsh Road, Calne
 Wiltshire, SN11 9BW, United Kingdom
 Tel +44 (0)1249 822 222 Fax: +44 (0)1249 822 300
 www.bilgroup.co.uk

TITLE

BZH100NPBJ

SIZE DWG NO.
 A4 BILCW03BZH100NPBJ_01

REV
 1

FILE NAME BILCW03BZH100NPBJ_01.PDF SHEET 1 OF 1