

**DRAWING DISCLAIMER**  
 COPYRIGHT OF THIS DRAWING IS RESERVED BY BIL GROUP LTD. IT IS ISSUED ON CONDITION THAT IT IS NOT REPRODUCED, COPIED, OR DISCLOSED TO A THIRD PARTY EITHER WHOLLY OR IN PART WITHOUT THE CONSENT IN WRITING OF BIL GROUP LTD.

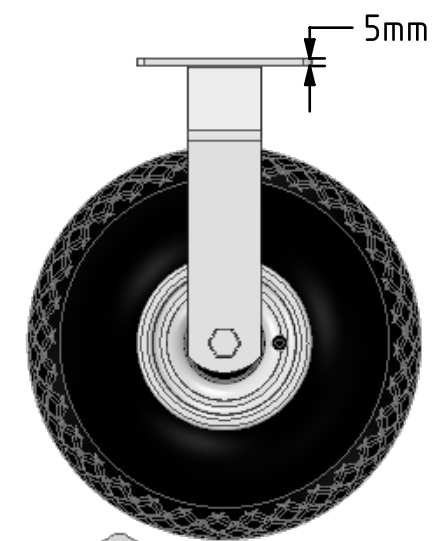

**Description:**  
 BZFPCF260MRB

Fabricated fixed castor with a top plate fixing fitted with a 4 ply black diamond pattern pneumatic tyre with a grey steel centre and roller bearing. Wheel diameter 260, tread width 85mm, overall height 318mm, plate size 115mm x 105mm, hole centres 92mm x 67 or 76mm x 76mm. Load capacity 200kg at max speed 4KPH, for non-towing applications

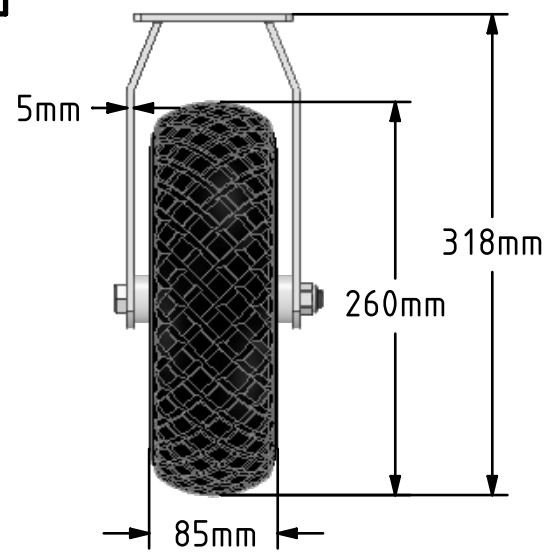
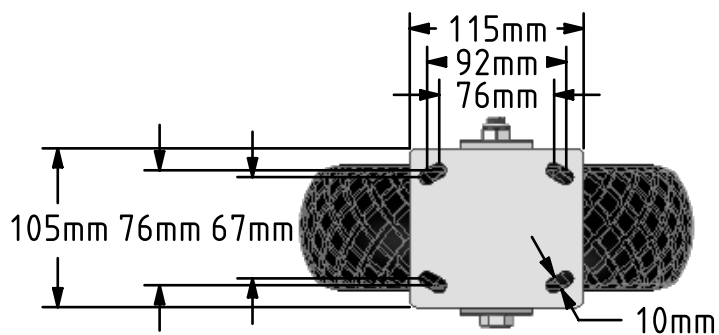

	NAME	DATE
DRAWN	Matt	09/01/19
APPROVED BY	Tim W	09/01/19
SCALE	1:5	09/01/19
WEIGHT	3.08kg	09/01/19

 BIL Group Ltd, Porte Marsh Road, Calne  
 Wiltshire, SN11 9BW, United Kingdom  
 Tel +44 (0)1249 822 222 Fax: +44 (0)1249 822 300  
 www.bilgroup.co.uk

TITLE	BZFPCF260MRB	
-------	--------------	--

UNLESS OTHERWISE SPECIFIED DIMENSIONS ARE IN MILLIMETRES

Unspecified Tolerances  
 Machining ± 0.25mm  
 Fabrication ± 1mm

SIZE	DWG NO.	REV
A4	BILCW03BZFPCF260MRB_01	1
FILE NAME	BILCW03BZFPCF260MRB_01.PDF SHEET 1 OF 1	