

DRAWING DISCLAIMER  
 COPYRIGHT OF THIS DRAWING IS RESERVED BY BIL GROUP LTD. IT IS ISSUED ON CONDITION THAT IT IS NOT REPRODUCED, COPIED, OR DISCLOSED TO A THIRD PARTY EITHER WHOLLY OR IN PART WITHOUT THE CONSENT IN WRITING OF BIL GROUP LTD.

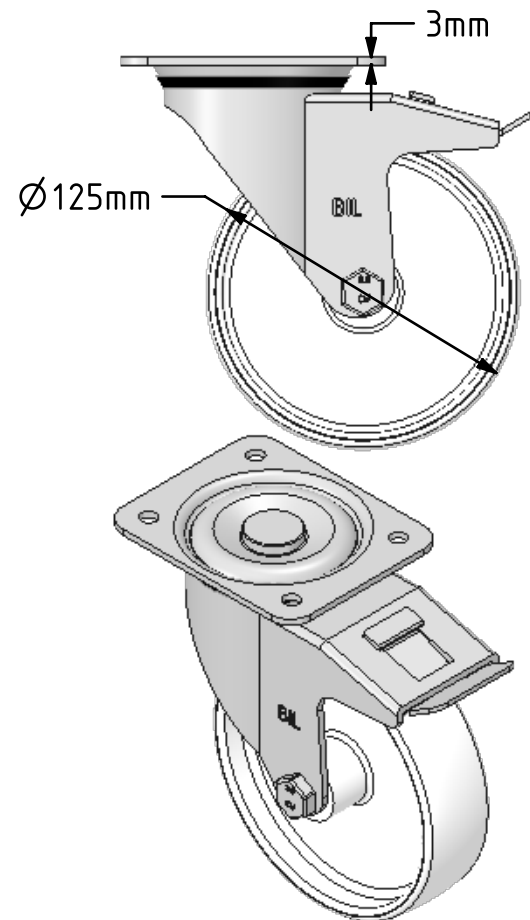

Description:  
 BZEH125NYSWB

Pressed steel swivel castor with a top plate fixing fitted with a white nylon wheel with a plain bearing and total lock brake. Wheel diameter 125mm tread width 35mm, overall height 155mm, top plate 105mm x 86mm, hole centres 80mm x 60mm. Load capacity 250kg.

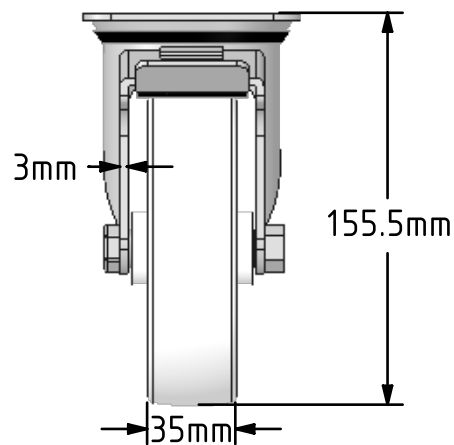
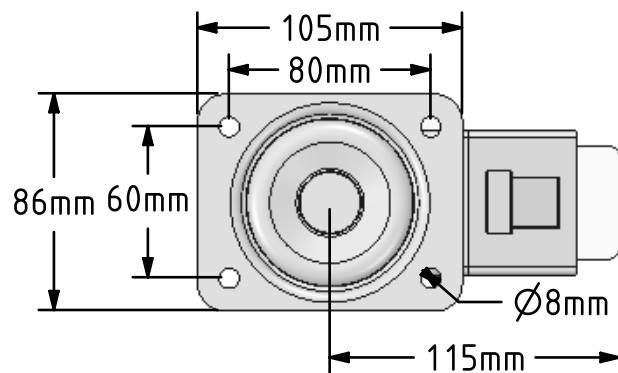

	NAME	DATE
DRAWN	Matt	26/07/18
APPROVED BY	Tim W	26/07/18
SCALE	1:3	26/07/18
WEIGHT	1.098kg	26/07/18

UNLESS OTHERWISE SPECIFIED DIMENSIONS ARE IN MILLIMETRES

Unspecified Tolerances  
 Machining ± 0.25mm  
 Fabrication ± 1mm



BIL Group Ltd, Porte Marsh Road, Calne  
 Wiltshire, SN11 9BW, United Kingdom  
 Tel +44 (0)1249 822 222 Fax: +44 (0)1249 822 300  
 www.bilgroup.co.uk

TITLE

BZEH125NYSWB

SIZE DWG NO.

A4

BILCW03BZEH125NYSWB\_01

REV

1

FILE NAME

BILCW03BZEH125NYSWB\_01.PDF

SHEET 1 OF 1