

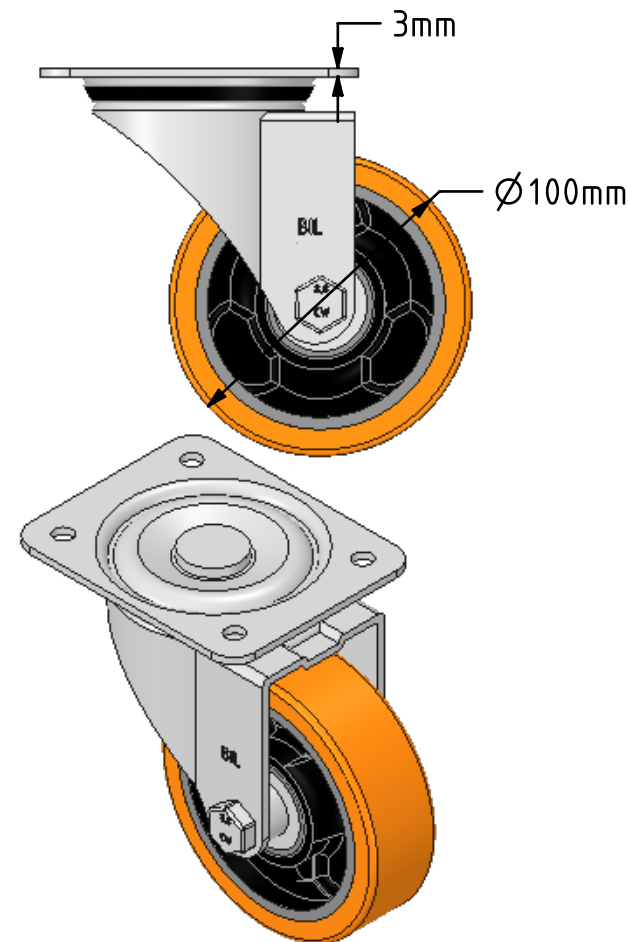

DRAWING DISCLAIMER
 COPYRIGHT OF THIS DRAWING IS RESERVED BY BIL GROUP LTD. IT IS ISSUED ON CONDITION THAT IT IS NOT REPRODUCED, COPIED, OR DISCLOSED TO A THIRD PARTY EITHER WHOLLY OR IN PART WITHOUT THE CONSENT IN WRITING OF BIL GROUP LTD.

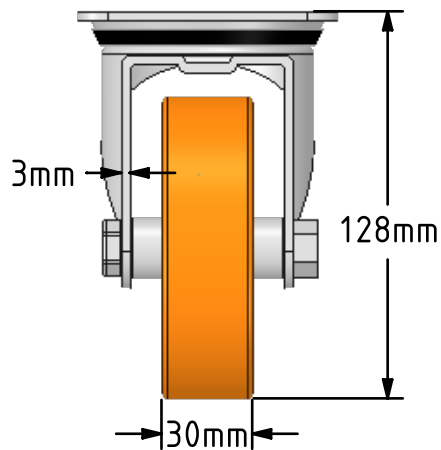
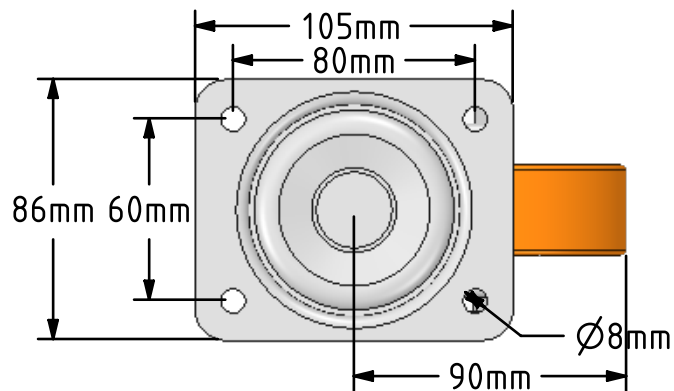
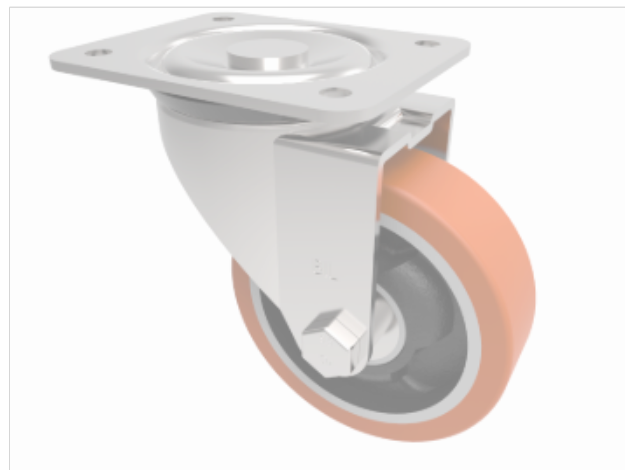

Description:
 BZEH100PTBJ

Pressed steel swivel castor with a top plate fixing fitted with a polyurethane tyred wheel on cast iron centre with ball bearings. Wheel diameter 100mm, tread width 30mm, overall height 128mm, top plate 105mm x 86mm, hole centres 80mm x 60mm. Load capacity 250kg.



	NAME	DATE	BIL Group Ltd, Porte Marsh Road, Calne Wiltshire, SN11 9BW, United Kingdom Tel +44 (0)1249 822 222 Fax: +44 (0)1249 822 300 www.bilgroup.co.uk	
DRAWN	Matt	26/01/18		
APPROVED BY	Chris	26/01/18		
SCALE	2.5	26/01/18		
WEIGHT	1.456kg	26/01/18		
UNLESS OTHERWISE SPECIFIED DIMENSIONS ARE IN MILLIMETRES			TITLE	
Unspecified Tolerances Machining ± 0.25mm Fabrication ± 1mm			BZEH100PTBJ	
SIZE		DWG NO.	REV	
A4		BILCW03BZEH100PTBJ_01	1	
FILE NAME			SHEET 1 OF 1	
BILCW03BZEH100PTBJ_01.PDF				