

DRAWING DISCLAIMER  
 COPYRIGHT OF THIS DRAWING IS RESERVED BY BIL GROUP LTD. IT IS ISSUED ON CONDITION THAT IT IS NOT REPRODUCED, COPIED, OR DISCLOSED TO A THIRD PARTY EITHER WHOLLY OR IN PART WITHOUT THE CONSENT IN WRITING OF BIL GROUP LTD.

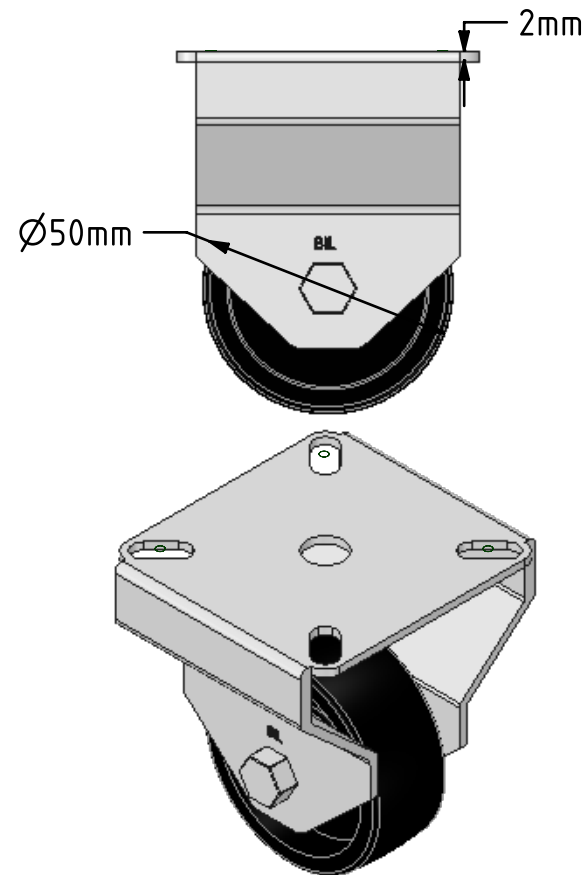

Description:  
 BZAF50PLLP

Pressed steel fixed castor with top plate fixing fitted with a black polypropylene wheel with plain bearing. Wheel diameter 50mm, tread width 20mm, overall height 72mm, plate size 60mm x 60mm, hole centres 46mm x 46. Load capacity 40kg.

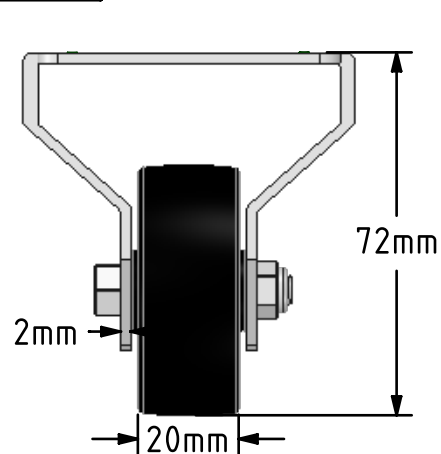
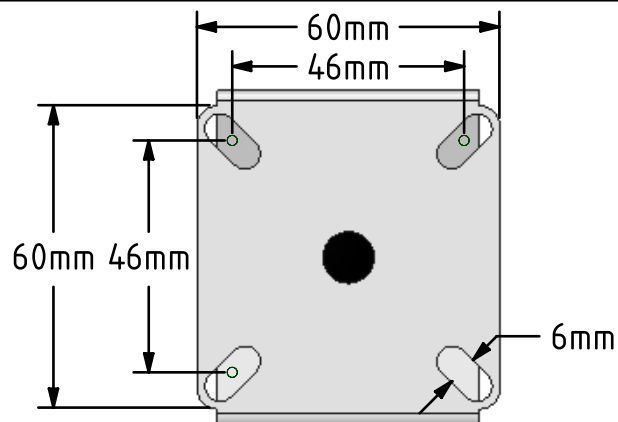

	NAME	DATE
DRAWN	Matt	26/02/18
APPROVED BY	Kevin	26/02/18
SCALE	2:3	26/02/18
WEIGHT	0.176kg	26/02/18

UNLESS OTHERWISE SPECIFIED DIMENSIONS ARE IN MILLIMETRES

Unspecified Tolerances  
 Machining ± 0.25mm  
 Fabrication ± 1mm



BIL Group Ltd, Porte Marsh Road, Calne  
 Wiltshire, SN11 9BW, United Kingdom  
 Tel +44 (0)1249 822 222 Fax: +44 (0)1249 822 300  
 www.bilgroup.co.uk

TITLE

BZAF50PLLP

SIZE DWG NO.

A4

BILCW03BZAF50PLLP\_01

REV

1

FILE NAME BILCW03BZAF50PLLP\_01.PDF

SHEET 1 OF 1