

DRAWING DISCLAIMER
 COPYRIGHT OF THIS DRAWING IS RESERVED BY BIL GROUP LTD. IT IS ISSUED ON CONDITION THAT IT IS NOT REPRODUCED, COPIED, OR DISCLOSED TO A THIRD PARTY EITHER WHOLLY OR IN PART WITHOUT THE CONSENT IN WRITING OF BIL GROUP LTD.

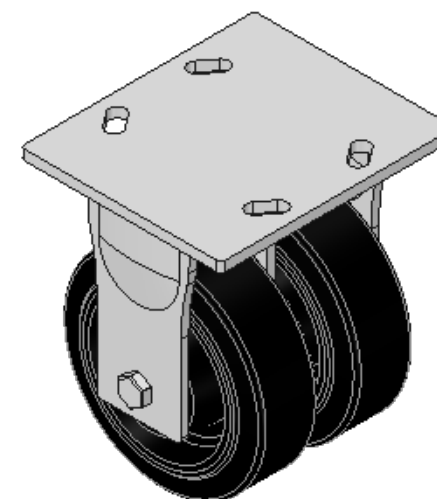

Description:
 2BZKF150CRBJ

Fabricated twin wheel fixed castor with a top plate fixing fitted with 2 x black elastic rubber tyred cast iron centred wheels with ball bearings. Wheel diameters 150mm, tread width 50mm x2, overall height 200mm, top plate 175mm x 150mm, hole centres 105mm x 80mm or 175mm x 150mm. Load capacity 700kg.

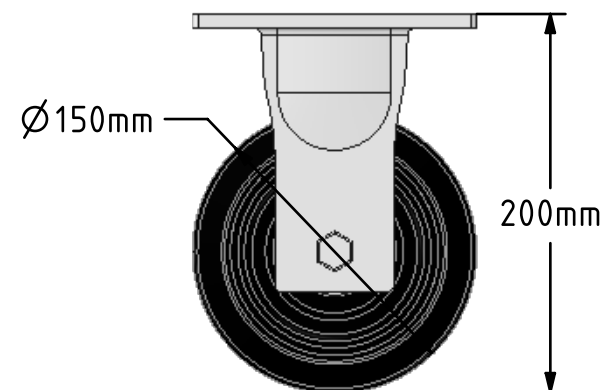
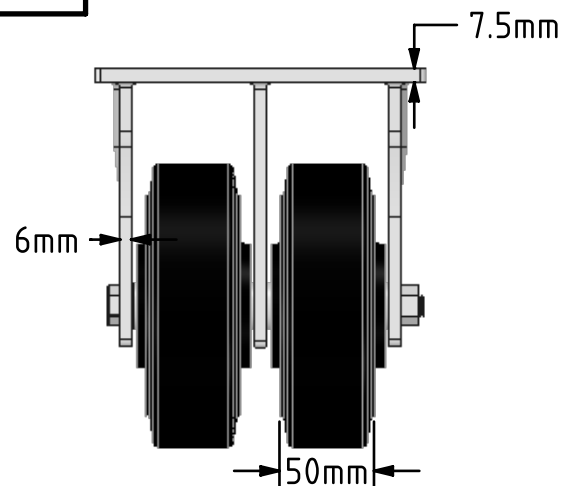
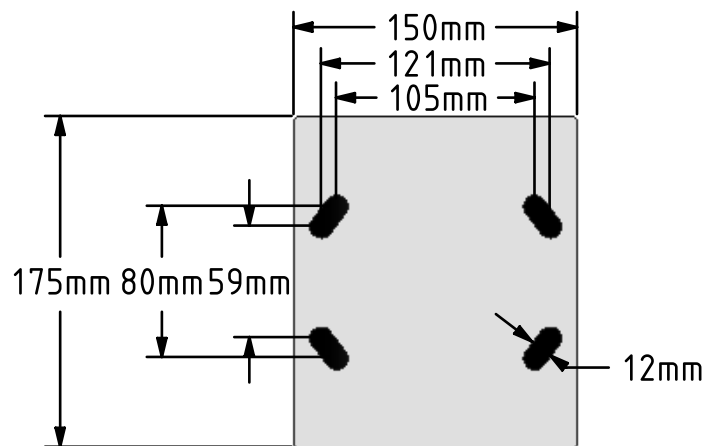

	NAME	DATE
DRAWN	Matt	21/05/18
APPROVED BY	Chris	21/05/18
SCALE	1:4	21/05/18
WEIGHT	8.1kg	21/05/18

UNLESS OTHERWISE SPECIFIED DIMENSIONS ARE IN MILLIMETRES

Unspecified Tolerances
 Machining ± 0.25mm
 Fabrication ± 1mm



BIL Group Ltd, Porte Marsh Road, Calne
 Wiltshire, SN11 9BW, United Kingdom
 Tel +44 (0)1249 822 222 Fax: +44 (0)1249 822 300
 www.bilgroup.co.uk

TITLE

2BZKF150CRBJ

SIZE DWG NO.

A4

BILCW032BZKF150CRBJ_01

REV

1

FILE NAME BILCW032BZKF150CRBJ_01.PDF

SHEET 1 OF 1