

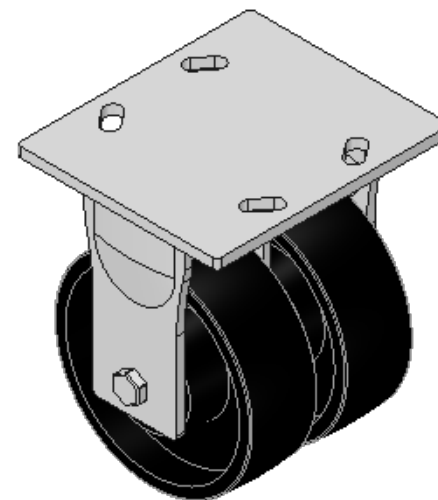

DRAWING DISCLAIMER
 COPYRIGHT OF THIS DRAWING IS RESERVED BY BIL GROUP LTD. IT IS ISSUED ON CONDITION THAT IT IS NOT REPRODUCED, COPIED, OR DISCLOSED TO A THIRD PARTY EITHER WHOLLY OR IN PART WITHOUT THE CONSENT IN WRITING OF BIL GROUP LTD.

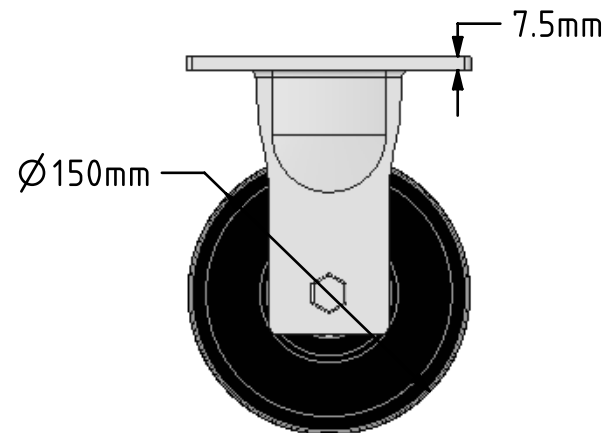
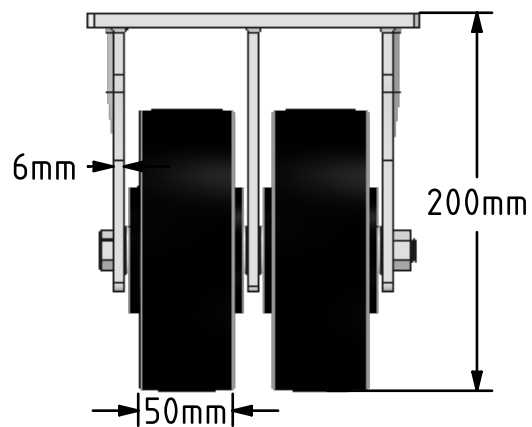
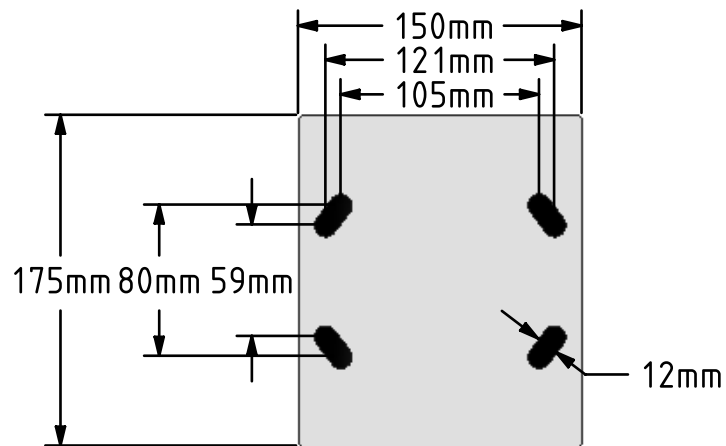

Description:
 2BZKF150CIBJ

Twin-wheeled fabricated swivel castor with a top plate fixing fitted with 2 x solid cast iron wheels with ball journal bearings. Wheel diameter 150mm, tread width 50mm, overall height 200mm, top plate 175mm x 150mm, hole centers 105mm x 80mm or 121mm x 59mm. Load capacity 1500kg.



	NAME	DATE	BIL Group Ltd, Porte Marsh Road, Calne Wiltshire, SN11 9BW, United Kingdom Tel +44 (0)1249 822 222 Fax: +44 (0)1249 822 300 www.bilgroup.co.uk	
DRAWN	Matt	21/05/18		
APPROVED BY	Chris	21/05/18		
SCALE	1:4	21/05/18		
WEIGHT	9.514kg	21/05/18		
UNLESS OTHERWISE SPECIFIED DIMENSIONS ARE IN MILLIMETRES			TITLE	
Unspecified Tolerances Machining ± 0.25mm Fabrication ± 1mm			2BZKF150CIBJ	
SIZE		DWG NO.	REV	
A4		BILCW032BZKF150CIBJ__01	1	
FILE NAME			BILCW032BZKF150CIBJ__01.PDF	SHEET 1 OF 1