

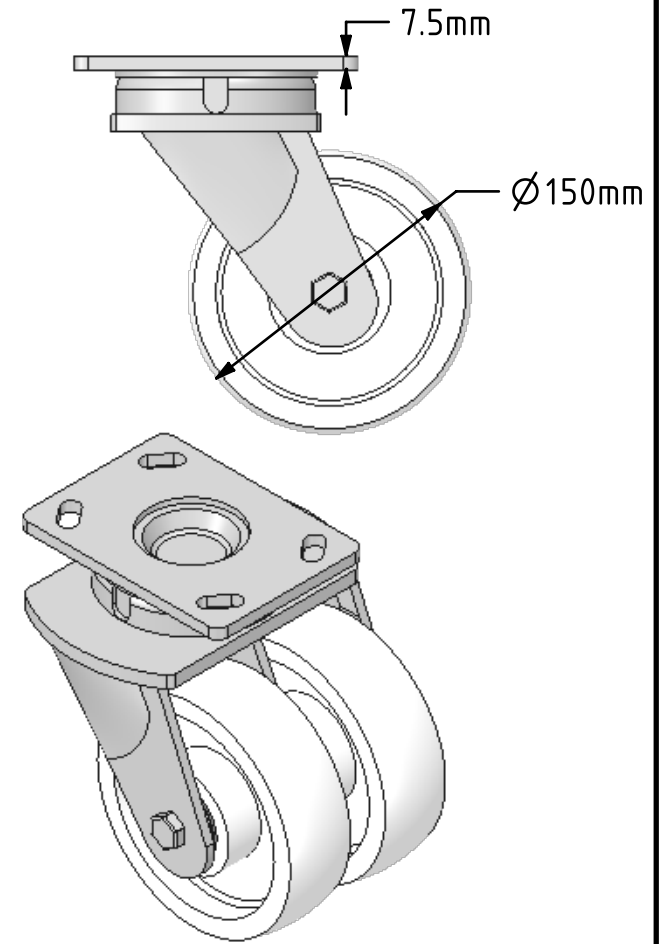

**DRAWING DISCLAIMER**  
 COPYRIGHT OF THIS DRAWING IS RESERVED BY BIL GROUP LTD. IT IS ISSUED ON CONDITION THAT IT IS NOT REPRODUCED, COPIED, OR DISCLOSED TO A THIRD PARTY EITHER WHOLLY OR IN PART WITHOUT THE CONSENT IN WRITING OF BIL GROUP LTD.

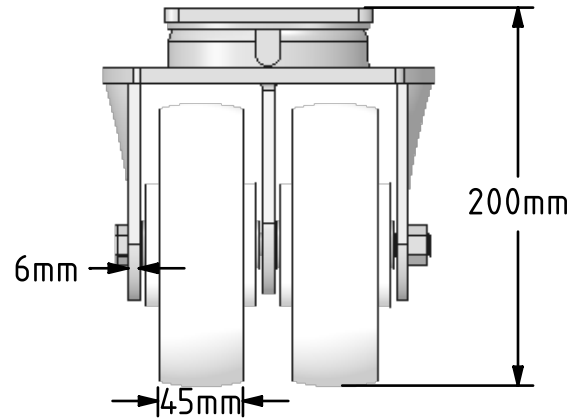
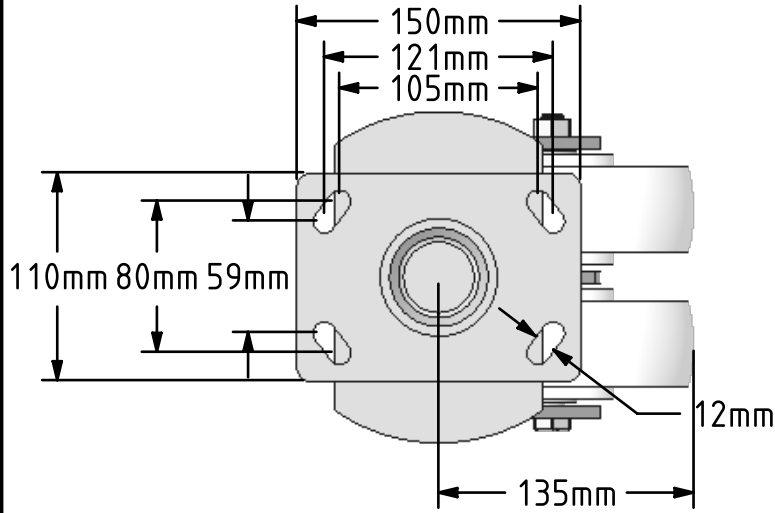

**Description:**  
 2BZK150NYBJ

Twin wheeled fabricated swivel castor with a top plate fixing fitted with 2 x white nylon wheels with ball bearings. Wheel diameter 2 x 150mm, tread width 2 x 45mm, overall height 200mm, top plate 150mm x 110mm, hole centres 105mm x 80mm or 121mm x 59mm. Load capacity 1500kg.



	NAME	DATE	BIL Group Ltd, Porte Marsh Road, Calne Wiltshire, SN11 9BW, United Kingdom Tel +44 (0)1249 822 222 Fax: +44 (0)1249 822 300 www.bilgroup.co.uk	
DRAWN	Matt	18/05/18		
APPROVED BY	Chris	18/05/18		
SCALE	1:4	18/05/18		
WEIGHT	5.999kg	18/05/18		
UNLESS OTHERWISE SPECIFIED DIMENSIONS ARE IN MILLIMETRES			SIZE	DWG NO.
Unspecified Tolerances Machining ± 0.25mm Fabrication ± 1mm			A4	BILCW032BZK150NYBJ_01
			TITLE	REV
			2BZK150NYBJ	
			FILE NAME	SHEET 1 OF 1
			BILCW032BZK150NYBJ_01.PDF	1