

DRAWING DISCLAIMER
 COPYRIGHT OF THIS DRAWING IS RESERVED BY BIL GROUP LTD. IT IS ISSUED ON CONDITION THAT IT IS NOT REPRODUCED, COPIED, OR DISCLOSED TO A THIRD PARTY EITHER WHOLLY OR IN PART WITHOUT THE CONSENT IN WRITING OF BIL GROUP LTD.

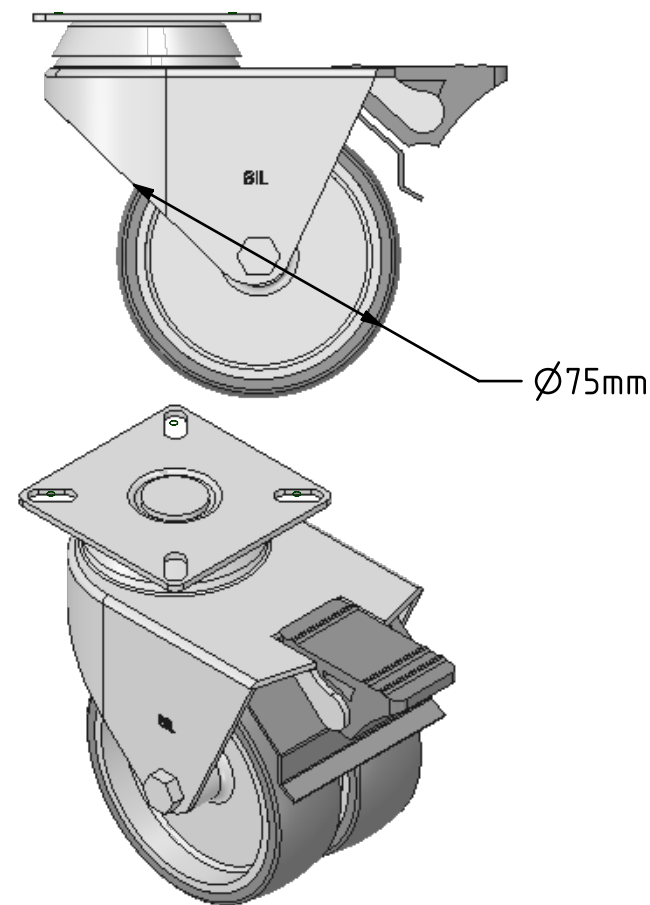

Description:
 2BZA75VGRSWB

Twin wheeled pressed steel swivel castor with a top plate fixing fitted with 2 thermoplastic grey rubber tyres on grey polypropylene centred wheels with plain bearings and total lock brake. Wheel diameter 75mm, tread width 2 x 24mm, overall height 101mm, plate size 60mm x 60mm, hole centres 46mm x 46mm Load capacity 80kg.

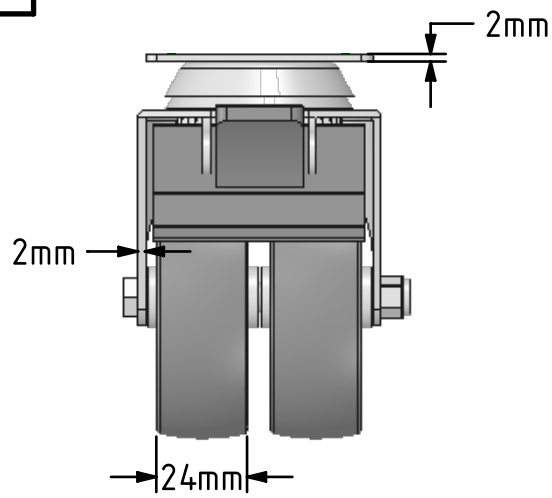
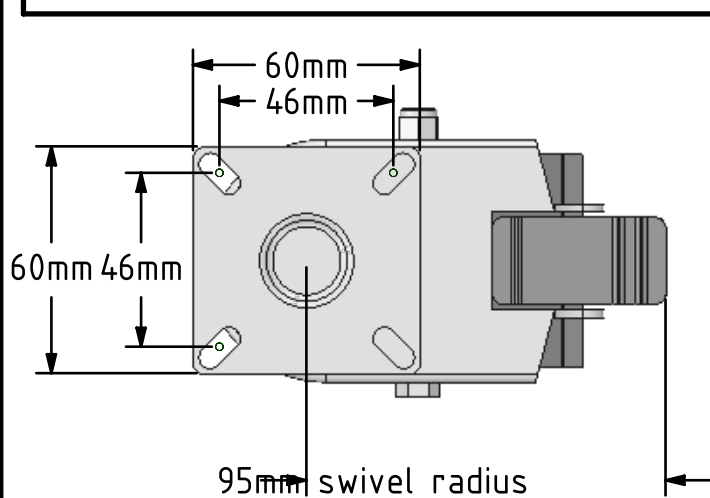

	NAME	DATE
DRAWN	Matt	09/06/16
APPROVED BY	Tim W	09/06/16
SCALE	1:2	09/06/16
WEIGHT	0.584kg	09/06/16

 BIL Group Ltd, Porte Marsh Road, Calne
 Wiltshire, SN11 9BW, United Kingdom
 Tel +44 (0)1249 822 222 Fax: +44 (0)1249 822 300
 www.bilgroup.eu

TITLE
2BZA75VGRSWB

UNLESS OTHERWISE SPECIFIED DIMENSIONS ARE IN MILLIMETRES
 Unspecified Tolerances
 Machining ± 0.25mm
 Fabrication ± 1mm

SIZE	DWG NO.	REV
A4	BILCW032BZA75VGRSWB_01	1
FILE NAME BILCW032BZA75VGRSWB_01.PDF		SHEET 1 OF 1