

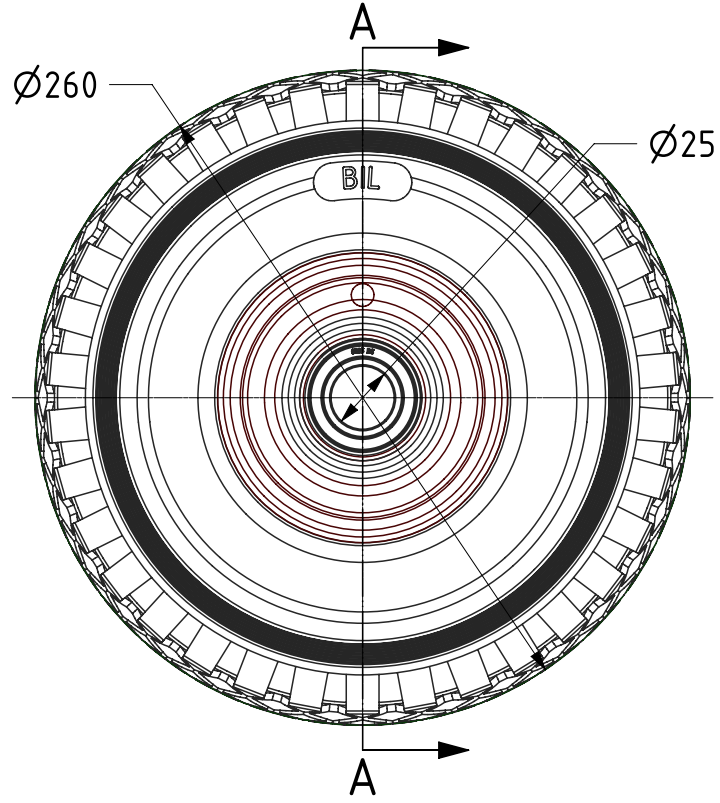

ITEM NO.	PART NUMBER	QTY
1	TYRE260PUD/LITE	1
2	RIM300X4STRED6204X65	1
3	BEARING6005	2

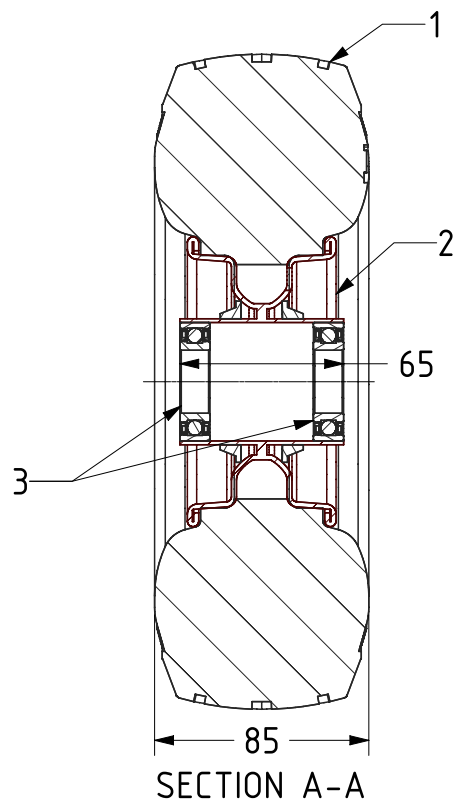

UNLESS OTHERWISE SPECIFIED DIMENSIONS ARE IN MILLIMETRES

Unspecified Tolerances
Machining ± 0.25mm
Fabrication ± 1mm

DRAWING DISCLAIMER

COPYRIGHT OF THIS DRAWING IS RESERVED BY BIL GROUP LTD. IT IS ISSUED ON CONDITION THAT IT IS NOT REPRODUCED, COPIED, OR DISCLOSED TO A THIRD PARTY EITHER WHOLLY OR IN PART WITHOUT THE CONSENT IN WRITING OF BIL GROUP LTD.

	NAME	DATE
DRAWN	Matt	31/10/22
APPROVED BY	Kevin	31/10/22
SCALE	1:3	
WEIGHT	1.812kg	



BIL Group Ltd, Porte Marsh Road, Calne
Wiltshire, SN11 9BW, United Kingdom
Tel +44 (0)1249 822 222 Fax: +44 (0)1249 822 300
www.bilgroup.co.uk

DWG NO.	BZWMPUB2602565DLITE	REV	1
BZWMPUB2602565D/LITE SHEET 1 OF 1			