

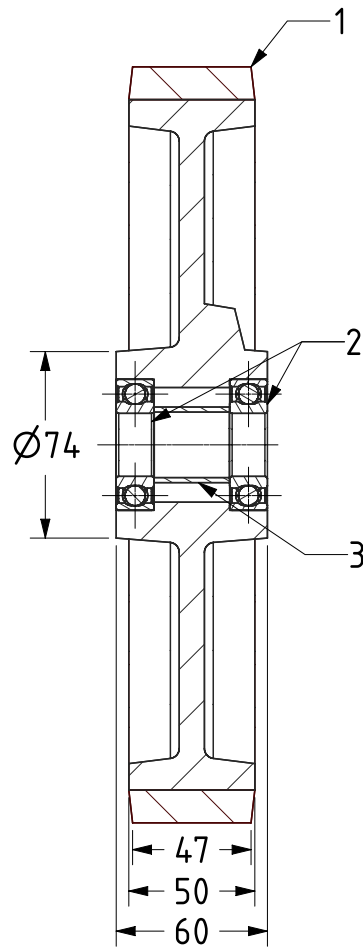

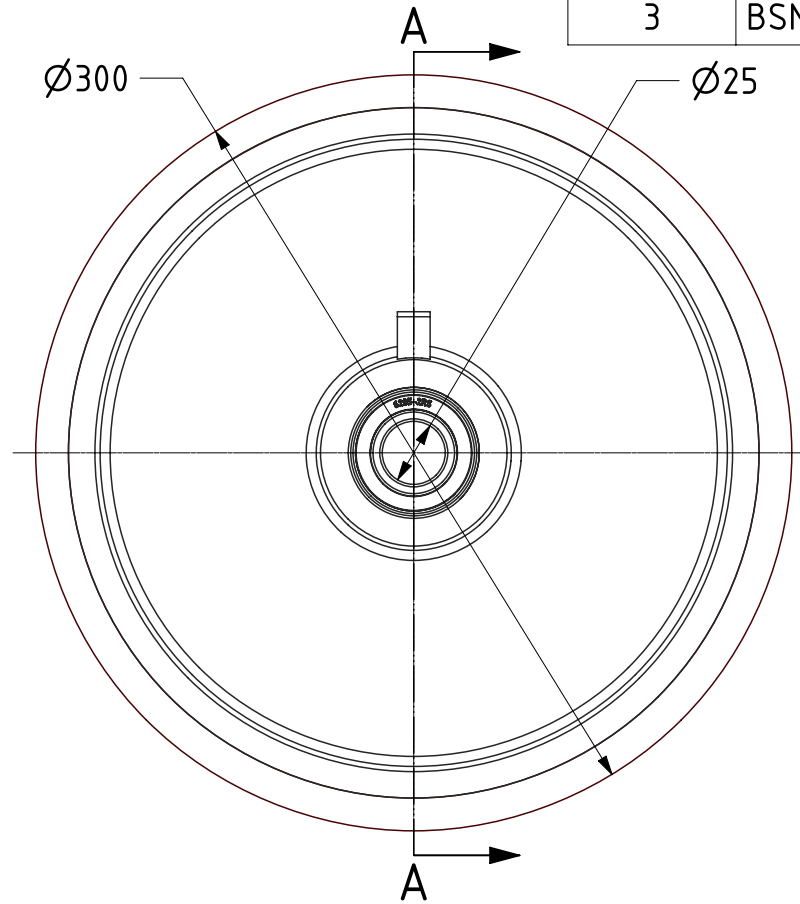

| ITEM NO. | PART NUMBER | QTY |
|----------|---------------|-----|
| 1 | BZPMH300WPTBJ | 1 |
| 2 | BEARING6205 | 2 |
| 3 | BSM25XM30 | 1 |



SECTION A-A



| | | | | | |
|---|--|-------------|--------|--------------|---|
| UNLESS OTHERWISE SPECIFIED DIMENSIONS ARE IN MILLIMETRES Unspecified Tolerances Machining ± 0.25mm Fabrication ± 1mm | DRAWING DISCLAIMER COPYRIGHT OF THIS DRAWING IS RESERVED BY BIL GROUP LTD. IT IS ISSUED ON CONDITION THAT IT IS NOT REPRODUCED, COPIED, OR DISCLOSED TO A THIRD PARTY EITHER WHOLLY OR IN PART WITHOUT THE CONSENT IN WRITING OF BIL GROUP LTD. | | NAME | DATE |  BIL Group Ltd, Porte Marsh Road, Calne Wiltshire, SN11 9BW, United Kingdom Tel +44 (0)1249 822 222 Fax: +44 (0)1249 822 300 www.bilgroup.co.uk |
| | | DRAWN | Matt | 27/04/22 | |
| | | APPROVED BY | Chris | 27/04/22 | |
| | | SCALE | 1:3 | | |
| | | WEIGHT | 8.71kg | | |
| DWG NO. BZPMH300WPTBJM25 | | | | REV 1 | |
| BZPMH300WPTBJM25 | | | | SHEET 1 OF 1 | |