

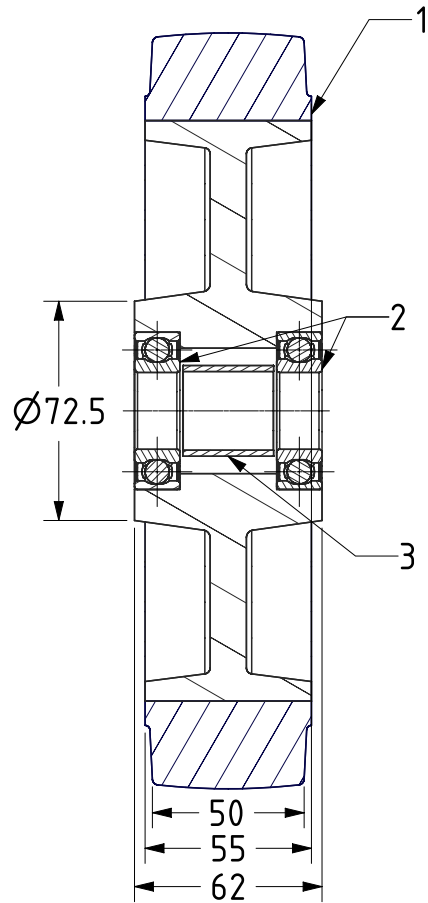

ITEM NO.	PART NUMBER	QTY
1	BZH250WRNBJ	1
2	BEARING6205X1	2
3	BSM25XM30	1

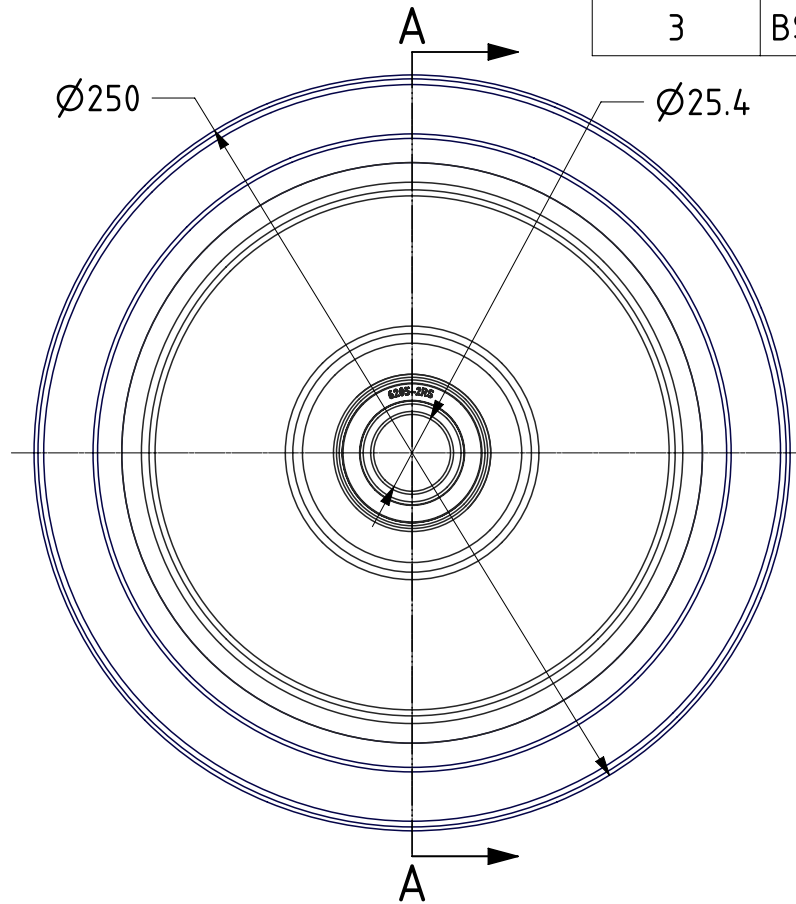

SECTION A-A



UNLESS OTHERWISE SPECIFIED DIMENSIONS ARE IN MILLIMETRES

Unspecified Tolerances  
Machining ± 0.25mm  
Fabrication ± 1mm

DRAWING DISCLAIMER

COPYRIGHT OF THIS DRAWING IS RESERVED BY BIL GROUP LTD. IT IS ISSUED ON CONDITION THAT IT IS NOT REPRODUCED, COPIED, OR DISCLOSED TO A THIRD PARTY EITHER WHOLLY OR IN PART WITHOUT THE CONSENT IN WRITING OF BIL GROUP LTD.

	NAME	DATE
DRAWN	Matt	20/12/21
APPROVED BY	Nathan	20/12/21
SCALE	2:5	
WEIGHT	2.345kg	

BIL Group Ltd, Porte Marsh Road, Calne Wiltshire, SN11 9BW, United Kingdom  
Tel +44 (0)1249 822 222 Fax: +44 (0)1249 822 300  
www.bilgroup.co.uk

DWG NO.	BZH250WRNBJM254	REV 1
BZH250WRNBJM254		SHEET 1 OF 1