

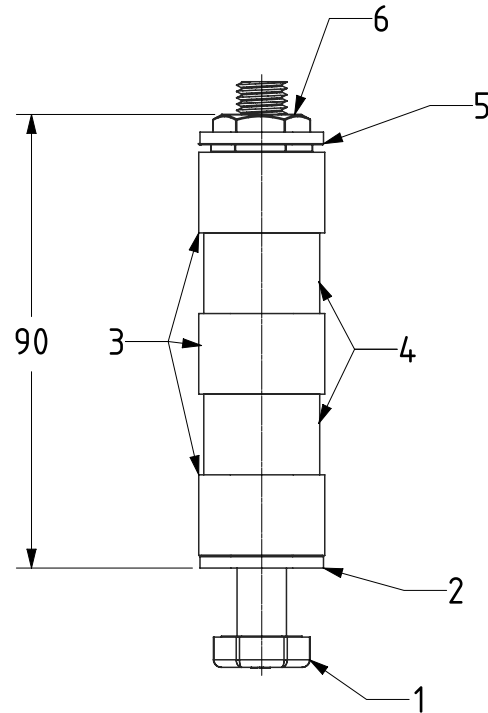

Ø25 to 28

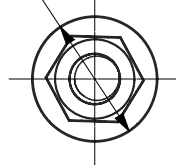

ITEM NO.	PART NUMBER	QTY
1	BOLTM10X110Z8.8	1
2	BZAEXR25WM	1
3	BZAEXR25RUB	3
4	BZAEXR25NY	2
5	BZAEXR25WMHEX	1
6	BZAEXNUT	1

UNLESS OTHERWISE SPECIFIED DIMENSIONS ARE IN MILLIMETRES

Unspecified Tolerances  
Machining ± 0.25mm  
Fabrication ± 1mm

DRAWING DISCLAIMER

COPYRIGHT OF THIS DRAWING IS RESERVED BY BIL GROUP LTD. IT IS ISSUED ON CONDITION THAT IT IS NOT REPRODUCED, COPIED, OR DISCLOSED TO A THIRD PARTY EITHER WHOLLY OR IN PART WITHOUT THE CONSENT IN WRITING OF BIL GROUP LTD.

	NAME	DATE
DRAWN	Matt	31/01/23
APPROVED BY	Kevin	31/01/23
SCALE	2:3	
WEIGHT	0.143kg	

	BIL Group Ltd, Porte Marsh Road, Calne, Wiltshire, SN11 9BW, United Kingdom Tel +44 (0)1249 822 222 www.bilgroup.co.uk	
	DWG NO. BZAEXR25XL	REV 1
BZAEXR25XL		SHEET 1 OF 1