

Black Rubber Steel Swivel Braked Expander 100mm 70kg

Product code: BZBC100BSBSWBEXS18

Pressed steel swivel castor fitted with a 18.5mm to 21mm square expander and a black rubber tyre on a steel disc centre wheel with a roller bearing bearing and total lock brake. Wheel diameter 100mm, tread width 26mm, overall height 126mm, Load capacity 70kg.

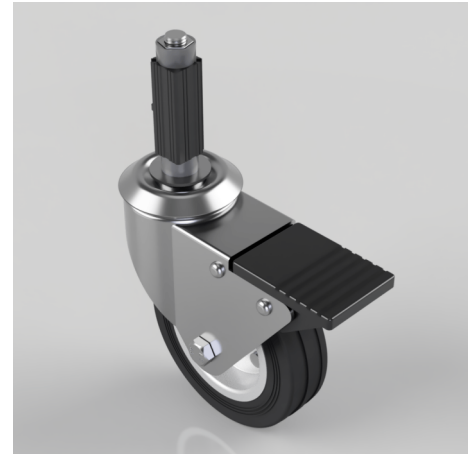

Height (mm)	126
Tread (mm)	26
Bearing Type	Roller
Diameter (mm)	100
Wheel Material	Rubber on Steel
Fixing Option	Bolt Hole, Expander
Castor Type	Swivel with Total Lock Brake
Load Capacity (kg)	70
Swivel Radius (mm)	115
Expander Type (mm)	Square Expander to Suit 18.5 - 21
Fork Thickness (mm)	2
Head Dia (mm)	60
Colour / Shore Hardness	Black Rubber on Steel Rim / 85 Shore A
Temperature Resistance	-20 °C TO +60 °C